

HARMONIC CONTROL AND REACTIVE POWER SYSTEM EXPERIENCE OF LARGE CHEMICAL MANUFACTURING FACILITY EXPANDED IN SIX STAGES

Copyright Material IEEE
Paper No. PCIC-2006-PH84

Bernd (Bernie) Schmidtke, P.Eng.
Member, IEEE
Universal Dynamics Ltd.
100-13700 International Place
Richmond, BC V6V 2X8 Canada
bschmidtke@udl.com

Abstract—Experience gained during the growth of a chemical manufacturing facility from a 65 MW to 170 MW load in multiple stages is presented. Large filter banks are required to control harmonic current and provide reactive power compensation for the rectifiers that energize the chemical process. As the load grows and the filters become large, utility generated harmonics are drawn into the filters resulting in difficulties complying with IEEE 519. The large size of the filters creates voltage rise issues for local equipment and the transmission system on load upset. Filters stress due to utility capacitor switching and in-plant filter element switching is compared for the initial load stages and the final load stage. Filter stress is reduced as the number and size of the filters is increased.

Index Terms — Harmonic Filters, IEEE 519, Chemical Rectifiers, Reactive Compensation, Switching Transient.

I. INTRODUCTION

Asset consolidation, growing product demand and favorable power costs have driven the expansion of this Chemical Manufacturing Facility in southern Manitoba, Canada to an electrical demand of 170 MW in 6 stages. This paper highlights the electrical system experience gained in the last 4 stages in which the load grew from 65 to 170 MW over a 4-year period.

II. LARGE FILTER BANKS AND THE UTILITY

A. Utility Generated Harmonics

Utility policies of KVA demand billing and strict compliance with harmonic limits have resulted in the deployment of large multi-element harmonic filter banks to supply reactive power and control harmonics. Although cost effective and reliable, these filter banks are large enough to draw in utility generated harmonic currents. For relatively small industrial installations this is not a problem, since the resulting currents are relatively small. However, as the load grows and the collective size of the filtering grows, the harmonic currents flowing from utility sources can be large enough that the currents exceed the permitted limits indicated in IEEE 519, the harmonic standard used by many utilities. This requires flexibility in how the standard is applied and requires that a special harmonic

compliance validation procedure be adopted to accommodate utility harmonics.

To illustrate, consider the electrical distribution system shown in Fig. 1, representing a typical single stage 45 MW chemical rectifier installation. Key components include the rectifier and rectifier transformer to supply high DC current at a voltage in the 200 to 500 Vdc range. Currents near 200 kA DC are not uncommon. The source side of the rectifier transformer is typically energized at 12.0 kV to 14.4 kV and is also the connection point of the harmonic filters. The utility side of the main supply transformer is typically energized at transmission level voltages, at 60 kV and up.

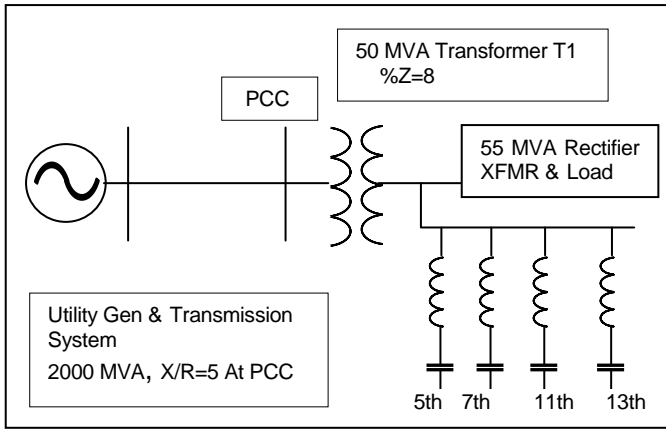

Fig. 1: Single Stage Rectifier

For any particular harmonic, the diagram of Fig. 1 can be reduced to its single phase equivalent, as shown in Fig. 2. Here, only one filter leg is shown since the low impedance in tuned filter branch of the harmonic under consideration is very low when compared to the impedance of other filter legs or transformer T1 and is considered zero in the discussions that follow. The impedance is of course never truly zero but this simplifying assumption does not introduce significant error, as can be shown by detailed calculations that do not include this simplification. The current I_r is the rectifier harmonic current and V_u is the utility source harmonic voltage, both at the harmonic under consideration. The primary side of T1 is labeled "PCC", or the "Point of Common Coupling". This is the utility connection point and where harmonic voltages and currents are measured. Since the impedance of the filter

branch ($Xl-Xc$) is taken as zero, point V_r is effectively connected to the Neutral and we can write equation (1) for the approximate current I_u , which is a function of the harmonic number, h .

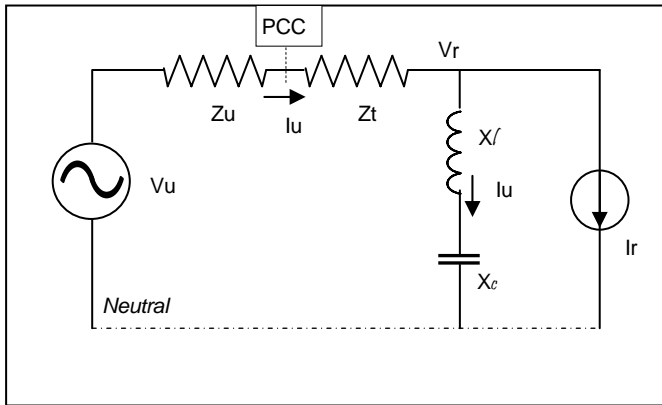

Fig. 2: Single Phase Equivalent

$$I_u(h) = \frac{V_u(h)}{Z_u(h) + Z_t \cdot h} \quad (1)$$

for $h=5,7,11, \dots, n$

Equation (1) is valid only for harmonics that have filter elements tuned such that the element impedance ($Xl-Xc$) is much less than the impedance of Z_u plus Z_t at that frequency. The letter “n” represents the harmonic number of the highest order filter element. This equation indicates the PCC current is a function of the harmonic impedance of the utility system combined with transformer T1 and the harmonic voltage of the Utility Source. With a combination of low impedance values for Z_u and Z_t and a large enough value of utility harmonic voltage, I_u can be sufficiently large that IEEE 519 limits applicable at the PCC are exceeded. It must be noted that this is without any contribution from the rectifier for which the harmonic filters are installed.

The following numerical support for the above is for the 5th harmonic but is believed to be applicable for higher order harmonics as well.

- 1) *IEEE 519 Utility Voltage Distortion Limits:* Table 11.1 of IEEE 519-1992 recommends “worst case” individual harmonic voltages distortion of 1.5% at the PCC for voltages in the 69 kV to 161 kV range. We use 1% for the calculations in TABLE I.
- 2) *IEEE 519 PCC Current Limits:* Table 10.4 gives 2% as the individual limit for $I_{sc}/I_L < 20$ and 3.5% as the limit for I_{sc}/I_L between 20 and 50, for harmonic numbers less than 11.
- 3) *TABLE 1:* This table compares the calculated and measured values of the ratio of 5th harmonic current to the fundamental at the PCC for the various stages of plant load growth. The table also provides the IEEE 519 permitted values.

TABLE I
STAGE 3 TO 6 COMPARISON

Proj. Stage	Plant Load MW	XFMR MVA	Z_u 5 th	Ratio of $I_u(5)/I_u(1)$		
				Calc.	IEEE 519 Table10.4	Meas. Ave
3	60	85	min	0.038	0.035	N/A
			max	0.018		
4	75	100	min	0.036	0.035	0.022
			max	0.016		
5	125	150	min	0.033	0.020	0.023
			max	0.011		
6	170	205	min	0.034	0.020	N/A
			max	0.008		

	R pu	X pu	
$Z_u(5)$ min	0.0848	-0.0451	$V_u(5) = .01$ pu
$Z_u(5)$ max	0.288	0.146	1 pu Power = 100 MVA

To aid in filter design, the utility provides the system harmonic impedance, given in TABLE 1 for the 5th harmonic. Both the min and max values are significantly less than the 0.25 pu impedance expected from the 2000 MVA system fault level. In addition, the minimum impedance reactance value is negative, which is largely responsible for our results.

The utility source harmonic voltage for the 5th harmonic is taken as 1.0% in the calculations, which is within the 1.5% permitted for the PCC in IEEE 519 and is generally considered to be below the threshold of causing problems. Actual measured values at the PCC have been recorded to be in the 1.5% range.

The results of TABLE I show that with a 1.0% utility 5th harmonic voltage and minimum system impedance, currents can be drawn into the customer's plant that exceed the limits permitted by the utility. Average measured values are lower than the worst case calculations. However, as the plant load increases and the short circuit to load current ratio decreases even the average measured values exceed the permitted limits.

The 2 to 3% 5th harmonic current does not cause a practical problem for the utility or its customer, provided the filters can handle the additional utility harmonic load. The customer is actually assisting the utility in reducing transmission level harmonic voltage by absorbing harmonic current in their filters. Accordingly, this problem is not a real problem, provided that the utility in its regulatory function recognizes that it can be the cause of harmonic voltage distortion and current flow. If there is an understanding that the customer will not be held to account for utility sourced harmonics, then the violation is not a true violation and the problem can be ignored. If required, to confirm the actual source of harmonics, the following tests can be executed:

- 1) With the rectifier disconnected and the filter off, monitor the harmonic voltage at the PCC (Fig. 1). This will establish which harmonic voltages are present and the extent to which they can act as a harmonic source. As seen above, even levels as low as 1.0% for low order harmonics such as the 5th can be significant.

- 2) Energize the filter while leaving the rectifier off. (Note that all filter elements must be energized so that higher order legs do not amplify the currents in lower order legs.) Recording the harmonic currents at the PCC will indicate the currents due to the utility as source. Record both magnitude and phase angle of significant currents.
- 3) Record the currents at the PCC again (magnitude and phase) with the rectifier on and the filter on.

Interpretation: If significant voltage harmonics recorded in step 1 match any of the filter leg harmonic numbers; and

If significant current harmonics (near or above IEEE 519 limits) are recorded in step 2; and

If the currents (magnitude and phase) do not change significantly in step 3, then the majority of harmonic current may be considered to be due to the utility. If the magnitude of the offending currents when comparing steps 2 and 3 are different, customer harmonics are a part factor.

B. Utility Generated Transients

The utility operates a generator plant with large capacitive reactive power banks in the near vicinity of the chemical plant. Utility studies confirm that capacitor switching will result in a transient resonant response in the 7th harmonic filters at the chemical plant. These were reported to be severe enough that protective consideration was recommended.

When Stage IV installation was planned, the threat to the proposed filter installation was evaluated. A filter transient response study was undertaken based on adding a 2 MVAR 7th filter for this 15 MW addition. The results showed that the filter would respond significantly and some protection was warranted in the form of a surge arrester installed across the capacitor portion of the filter, line to ground. The arrester would restrict the voltage rise across the capacitor to the arrester clip point and limit the transient response. Fig. 3 shows the simulated switching excitation and filter capacitor response.

A similar evaluation was conducted during the Phase V planning stage. This was a 42.5 MW plant addition with a 7th filter leg with a 7 MVAR sizing. This addition proved to be large enough that the transient event no longer provided sufficient energy to excite the filters to a danger point. Accordingly, no additional transient protection was added at Stage V and VI.

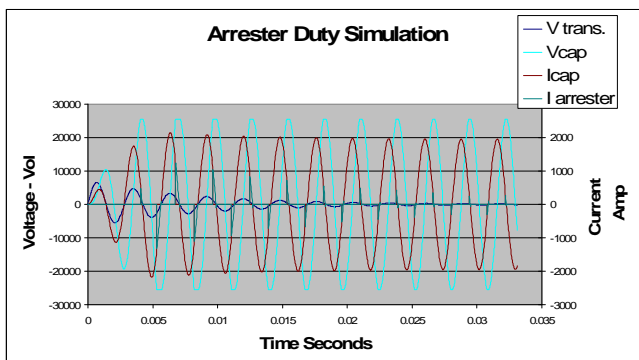

Fig. 3: 7th Filter Leg Transient Response

III. VOLTAGE ISSUES

A. Filter Energization

The load increase for Phase V involved a 42.5 MW rectifier with a 35 MVAR filter, the largest at the site. The size of the filter was increased above the reactive correction required for the rectifier to bring the entire site power factor to unity. To minimize the switching impact of such a large bank and to utilize standard capacitor rated circuit breakers the bank was split in two, so that the 5th and 7th banks were controlled from one breaker and the 11th and 13th from the other.

Switching simulations showed that the 12.47 kV bus voltage (rectifier connection point) had a 50% voltage ripple on switching the larger 11th+13th bank and a 25% ripple with the smaller bank. Concerns were raised that a 50% ripple may trigger rectifier surge arrester operation and possibly have a confusing impact on the thyristor firing timing logic. A solution was sought to avoid exposing the rectifier to the potentially damaging voltages. The 25% ripple of the 5th+7th bank is low enough that this was not considered to be a problem.

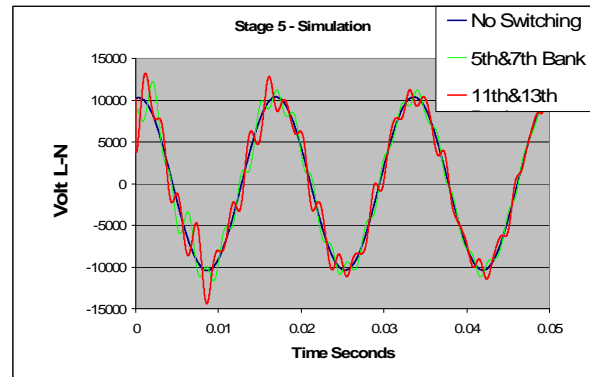

Fig. 4: Filter Energization—Rectifier Bus Voltage

To address this issue the decision was made to energize the 11th and 13th bank with the energization of the main transformer, prior to rectifier turn on. In this way the rectifier does not see the large energization voltage ripple. Once rectifier load is at 60% the smaller 5th+7th bank is energized to complete the system and prepare for full load.

This arrangement proved successful. The rectifier smoothly took on load to 60%, accepted the small filter switching transient and moved on to 100% load. The anticipated current harmonic amplification at the PCC of the 5th and 7th harmonic during the first 60% of the load cycle was calculated to be less than 2% THD. Actual measurements are not available, but the brief time period of the start-up load ramp ensured that this would not be problem.

B. Large Filter Voltage Rise

Capacitive reactive power is required to minimize operating costs, minimize losses, voltage drop and regulation for rectifier loads. When load is suddenly lost and the capacitors are left on by themselves, the voltage rise can be high and potentially damaging to the capacitors themselves and to other equipment.

At the completion of Stage 6, the total load was 170 MW and the total effective capacitive reactive power was 104 MVAR, resulting in a power factor near unity at the PCC.

With the sudden trip of a single rectifier, a voltage of 1.08 pu can be expected at the rectifier bus and 1.03 pu at the utility bus, in the first few cycles following a trip. These voltages become more severe if there is a simultaneous trip of more than one rectifier, possibly due to a common process condition or a utility disturbance. Rectifier and utility bus voltages of 1.14 pu and 1.08 pu, respectively, have been simulated immediately after a trip. Even higher voltages may result if the trip condition results in more load loss on the utility system and voltages near 1.2 pu are possible within the plant. Rapid filter bank tripping is required to avoid damage to the filters and other equipment from prolonged exposure to these high voltages.

Several factors combine in this installation so that the over-voltage protection has not been triggered and is not expected to be a significant problem. The first is that the site is within a few kilometers of a utility generating station. The utility provides a voltage controlled bus so that utility source bus voltages are restored to near nominal within the generator voltage regulator operating time of a load upset. This ensures that the impact on other customers and utility line equipment will be minimal.

The second factor is due to the use of mostly thyristor rectifiers at the plant. When these rectifiers are used in conjunction with capacitor filter banks, the combination results in a relatively stable VAR load, that is more like an inductor than a capacitor. While a filter supplies leading VARs that vary in proportion to the square of the applied voltage, a rectifier draws lagging VARs in accordance with the following relationship:

$$Q = \left\{ \left(\frac{V_r}{P_{f_1}} \right)^2 - 1 \right\}^{1/2} \quad (2)$$

where:

Q	Reactive Power at Rated Active Load In per unit
V _r	Rectifier Voltage, in per unit
P _{f₁}	Displacement Power Factor at Rated Load

For typical rectifier operation, the rectifier VAR load changes more aggressively with voltage than the filter. Fig. 5 shows the relationship between the change in voltage and VAR power due to filters and thyristor rectifiers, individually and in combination. Note the steeper slope of the rectifier VAR curve, resulting in a stabilizing characteristic: as the voltage increases, the system demands more lagging VARs, tending to decrease the voltage. Conversely, as the voltage decreases the system demands less VARs, tending to raise the voltage. Accordingly, if the voltage rise is not so severe that the rectifiers are tripped off, the rectifiers actually help to stabilize voltage.

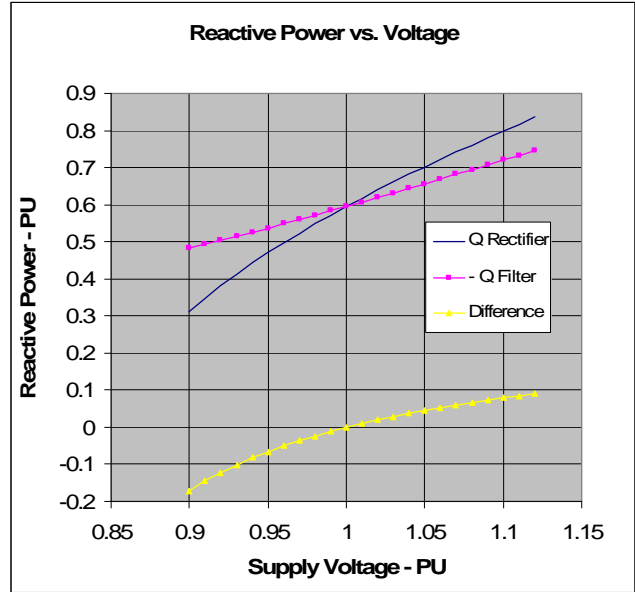

Fig. 5: Typical Filter and Rectifier Reactive Power

In addition to the two mitigating factors noted above, harmonic filters are frequently designed to accommodate the higher voltage stresses due to harmonics by selecting voltage ratings on filter capacitors greater than the system nominal voltage. Capacitor voltage rating factors between 1.05 to 1.2 pu are not uncommon. After the rectifiers trip, harmonic load drops immediately and the extra voltage rating is available to accommodate an overvoltage.

The combination of all these factors provides a robust installation that is relatively insensitive to voltage variations, in spite of the large array of filter banks.

IV. CONCLUSIONS

Harmonic currents at the point of Common Coupling can have both utility and customer sources. This paper identifies conditions where utility sources can be significant enough that customer PCC harmonic limits are violated. Provided that the customer's filters can accommodate the additional loading, this apparent violation becomes a non-issue. Problems associated with energizing large filter banks are identified with practical steps to circumventing these. In spite of the application of large filter banks and operation near unity power factor, actual system overvoltage is rare and not a problem at this installation.

V. ACKNOWLEDGEMENTS

The author wishes to thank Mr. Jack St. Mars and Mr. Bob McManus for their assistance in collecting data and Mr. Paul Buddingh for providing editorial enhancements and the "memory" of project events and details.

VII. REFERENCES

- [1] J.C. Read, "The Calculation of Rectifier and Inverter Performance Characteristics", *Proceedings of the IEEE*, Vol. 92, Part 2, No. 29, pp. 495-509, October 1945.
- [2] *IEEE Std. 399-1990*, "IEEE Recommended Practice for Power System Analysis".
- [3] D.E. Steeper and R.P. Stratford, "Reactive Power Compensation and Harmonic Suppression for Industrial Power Systems using Thyristor Converters," *IEEE Trans. IA-12*, 5/76 pp. 235-255.
- [4] David D. Shipp, "Harmonic Analysis and suppression for Electrical Systems supplying Static Power Converters and other Nonlinear Loads," *IEEE Transactions on Industry Application*, Vol. IA-15, No. 5, Sept/Oct 1979.
- [5] David E. Rice, "A detailed analysis of six pulse converter harmonic currents," *IEEE Transactions on Industry Applications*, Vol. 30, No. 2, March/April 1994.
- [6] J. Arrillaga et al, "Power System Harmonics," John Wiley & Sons, ISBN 0471906409, 1985.
- [7] *IEEE 519-1992* "IEEE Recommended Practices and Requirements for Harmonic Control in Electrical Power Systems".
- [8] J. Schaeffer, "Rectifier Circuits - Theory & Design," John Wiley & Sons, 1965.
- [9] P.C. Buddingh, "Even Harmonic Resonance - An unusual problem", *IEEE Transactions on Industry Applications*, Vol. 39, No. 4, July/August 2003.

VIII. VITA

Bernd (Bernie) Schmidtke graduated from the University of Alberta in 1984 with a BSc in Electrical Engineering. After graduation, Bernd worked at the University of Alberta as a Research Assistant in their Power Electronics group designing and simulating power converters. This was followed by 5 years of consulting engineering services to the Oil and Gas industries in Northern Alberta as a Design and Project Engineer for Colt Engineering Corp. In 1992, Bernd joined D.W. Thomson Consultants in Vancouver as an Associate to provide consulting services to the Municipal and Institutional sectors in British Columbia. For the past 10 years, Bernd has been active as a Design Engineer and Sr. Power Systems Engineer to the Pulp and Paper, Chemical and Lime Industries as an employee of Universal Dynamics Ltd. in Richmond, BC. Bernd is registered as a Professional Engineer in Alberta and British Columbia.