

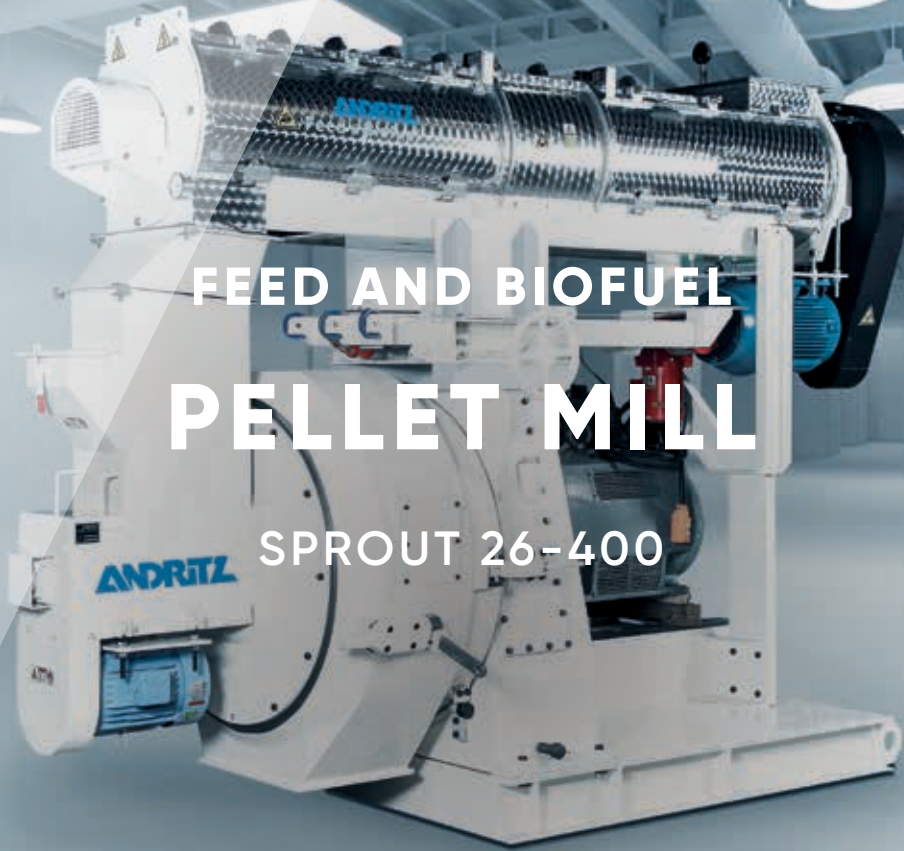

FEED AND BIOFUEL PELLET MILL

SPROUT 26-400



Over 30 years of pelleting and still improving. See the latest features:

- Left hand or right hand solid stainless steel door = no corrosion issues.
- Hardened gears, (bull gear is reversible to extend life).
- Removable cartridge assembly = change from pellets to cubes rapidly
- Tapered die fit, reversible die = change die in short time
- Major pelletmill components = hardened stainless steel = compact size, high strength
- Split tapered die wear rings = no tools needed for replacement

ANDRITZ

ENGINEERED SUCCESS

ADDITIONAL FEATURES & BENEFITS:

- Mill is designed and built in complete imperial units = no special metric threads
- Up to 400HP can be applied
- Two gearsets available = when need to slow mill for cubes
- Large tapered roller bearings for drive loads
- Dedicated roller bearing to handle pelleting loads
- Variety of roll shell designs from Rufftex™, corrugated, dimpled
- Adjustable feed plow to feed die evenly

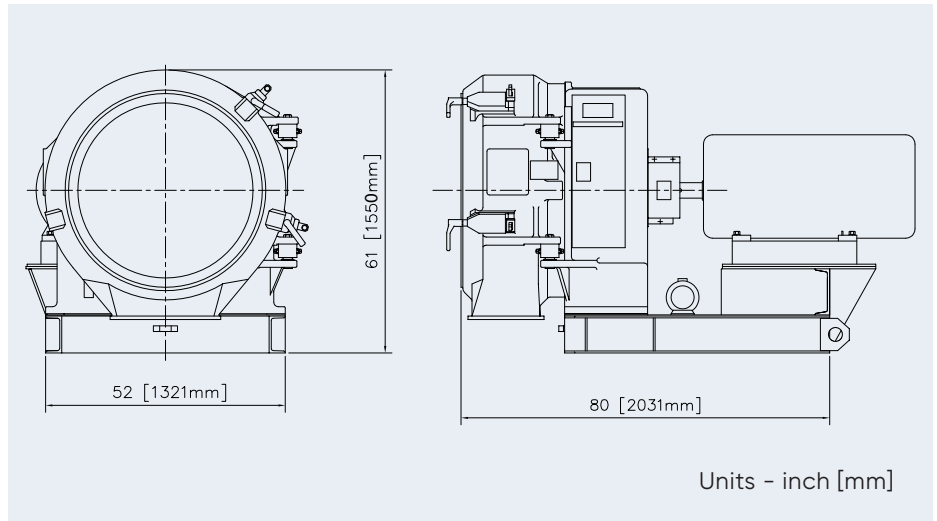

ANDRITZ MANUFACTURING & SERVICE:

- ANDRITZ manufactures its own dies so there is one source to contact
- ANDRITZ has a staffed service department with trained mechanics
- Manufacturing and engineering at same location in Muncy PA

OPTIONS:

- Hoist with tools to assist with die and roll assembly changes
- Centrifeeder to provide even feed to roll assemblies and maximize bearing, rollshell and die life
- Auto-greasing system for roll and main bearings
- Water or air oil cooling
- Carrier cart and pedestals for faster cartridge changes
- Conditioner with optional liquid(s) and/or steam addition
- Automatic roll adjust (2 roll pellet mill)

ANDRITZ Feed and Biofuel A/S

andritz-fb.dk@andritz.com

p: +45 72 160 300 / andritz.com/ft

TECHNICAL DATA

Model	Max HP	I.D.	Work width	Work area	No. rolls	Weight*
26-400			4 1/4 in. [108mm]	348 sq. in. [2245cm ²]	3	9,820 lb. [4454 kg]
26W-400	400 [298kW]	26 [660mm]	6 in. [152mm]	490 sq. in. [3162cm ²]	3	9,950 lb. [4513 kg]
26XW-400			8 in. [203mm]	653 sq. in. [4213cm ²]	3	10,380 lb. [4708 kg]

ANDRITZ Feed and Biofuel USA

andritz-fb.us@andritz.com

p: +1 570 546 1253

ANDRITZ

All data, information, statements, photographs and graphic illustrations in this leaflet are without any obligation and raise no liabilities to or form part of any sales contracts of ANDRITZ AG or any affiliates for equipment and/or systems referred to herein. © ANDRITZ AG 2018. All rights reserved. No part of this copyrighted work may be reproduced, modified or distributed in any form or by any means, or stored in any database or retrieval system, without the prior written permission of ANDRITZ AG or its affiliates. Any such unauthorized use for any purpose is a violation of the relevant copyright laws. ANDRITZ AG, Statterger Strasse 18, 8045 Graz, Austria.



1 0518

2603 US