



FEED AND BIOFUEL

BEST ACTIVATION OF NATURAL BINDERS

SHANGHAI CONDITIONER TYPE SCM AND SDDC

ANDRITZ

ENGINEERED SUCCESS

Best activation of natural binders

ANDRITZ has developed distinctive conditioner models designed to provide the best preparation of raw material prior to entering the pelleting or extrusion process. Conditioning is the most effective way of achieving excellent pellet quality. Using just the right combination of heat, moisture, and time, conditioning activates the naturally occurring binding components in plant materials and makes pelleting and extrusion easier and more efficient.

SCM CONDITIONER

The ANDRITZ SCM conditioner, manufactured in stainless steel, is characterized by a compact structure, low energy consumption, and a long working life. The machine adopts different structures for different kinds of feed, especially for shrimp feed. Extended conditioners and jacketed conditioners are optional, which helps to meet the different requirements, such as longer retention time, higher temperature, or both.

SCM conditioner



SDDC CONDITIONER

The ANDRITZ double-shaft conditioner is well suited for various kinds of materials. All parts coming in contact with feed are made of stainless steel for corrosion resistance and feed safety. It is equipped with two large-volume barrels for higher liquid addition as well bearings that are international recognized for their durability. A homogenous mix is achieved quickly and efficiently, thanks to the differential speed of the dual shafts.

SDDC conditioner



SCM CONDITIONER

Characterized by compact structure, low energy consumption and long working life.



SCM conditioner

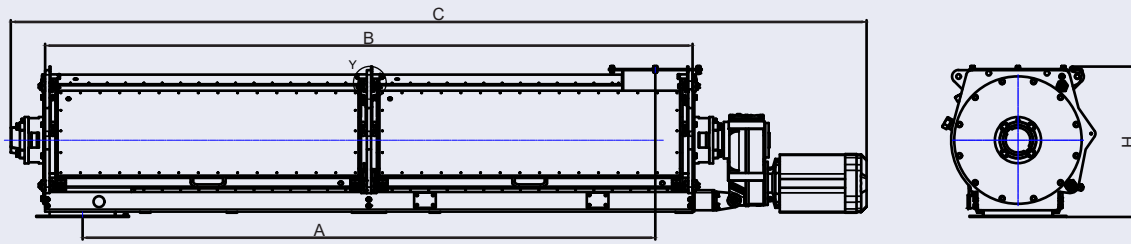

SDDC conditioner

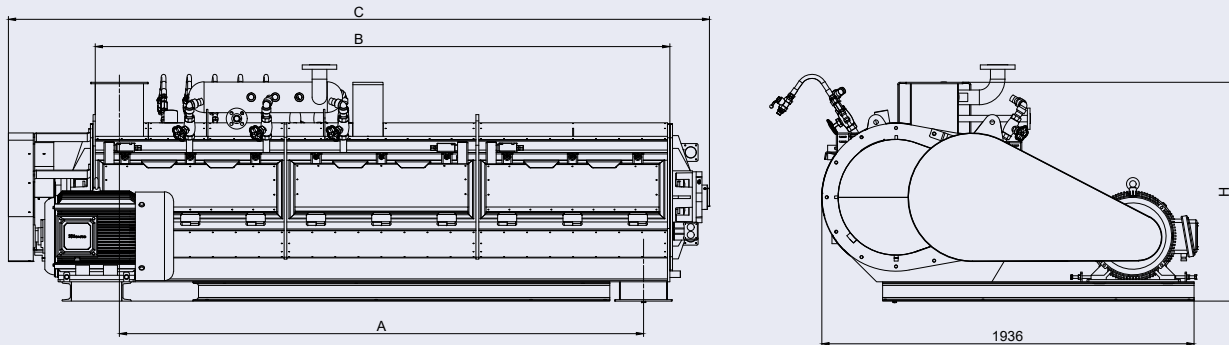

TECHNICAL SPECIFICATIONS

| Model | Transmission | Dimensions | Motor power | Inlet size | Outlet size | Shaft speed |
|---------|--------------------------|--------------------|-------------|------------|-------------|-------------|
| | | mm | kW/HP | mm | mm | rpm |
| SCM300 | Gearmotor | Ø400x2500 | 7.5/ 4P | 260x200 | 260x200 | 400 |
| SCM400 | Gearmotor | Ø400x3000 | 11/ 4P | 260x200 | 260x200 | 400 |
| SCM500 | Gearmotor | Ø500x2500 | 7.5/ 4P | 320x300 | 320x300 | 250 |
| SCM600 | Gearmotor | Ø500x3000 | 11/ 4P | 320x300 | 320x300 | 250 |
| SDDC680 | V Type Belt Open gear | Ø660/Ø520 x3000 | 22/6P | 260x260 | 194x400 | 140/280 |

DIMENSION SIZE (MM)

| Model | H | A | B | C |
|---------|------|------|------|------|
| SCM300 | 615 | 2254 | 2500 | 3422 |
| SCM400 | 615 | 2754 | 3000 | 3963 |
| SCM500 | 700 | 2154 | 2500 | 3463 |
| SCM600 | 700 | 2654 | 3000 | 3963 |
| SDDC680 | 1138 | 2726 | 3000 | 3648 |

Optimum conditioning results in the desired activation of natural binders by using heat, moisture, and time.



GLOBAL SUPPLIER – LOCAL PRESENCE

With sales, service, engineering, manufacturing and production sites located all around the world, ANDRITZ Feed and Biofuel is truly a global organization with a local presence. ANDRITZ is vital to ensuring a reliable global supply of aqua feed, animal feed, pet food, and biofuel. With full process lines accounting for half the world's production of aqua feed and biomass alone, we continuously support leading producers in achieving the highest levels in safety, quality, and control from feedstock to final product.

How can we help grow your business?

ANDRITZ Feed and Biofuel A/S

Glentevej 5-7
6705 Esbjerg, Denmark
p: +45 72 160 300
andritz-fb.dk@andritz.com

ANDRITZ (Shanghai) Equipment & Engineering Co., LTD

No.2288, Rongle East Road, Songjiang,
201613, Shanghai, P.R.China
p: +86 21 57745781
andritz-fb.cn@andritz.com

AUSTRALIA

p: +61 3 8773 4888
andritz-fb.au@andritz.com

CHINA

p: +86 21 5774 5781
andritz-fb.cn@andritz.com

INDIA

p: +91 87544 15287
andritz-fb.india@andritz.com

SOUTH AFRICA

p: +27 82 781 0808
andritz-fb.za@andritz.com

BANGLADESH

p: +88 (02) 9844800
andritz-fb.bd@andritz.com

COLOMBIA

p: +57 (1) 744 8200
andritz-fb.co@andritz.com

ITALY

p: +39 (0445) 575 695
andritz-fb.it@andritz.com

TURKEY

p: +90 232 570 38 00
andritz-fb.tr@andritz.com

BRAZIL

p: +55 47 3387 9146
andritz-fb.br@andritz.com

DUBAI

p: +971 4 299 5555
andritz-fb.uae@andritz.com

MEXICO

p: +52 443 323 1530 ext 364
andritz-fb.mx@andritz.com

UK

p: +44 1482 825119
andritz-fb.uk@andritz.com

CANADA

p: +1 519 676 7057
anbosales@andritz.com

FRANCE

p: +33 24 75 06 364
andritz-fb.fr@andritz.com

NETHERLANDS

p: +31 40 2627777
andritz-fb.nl@andritz.com

USA

p: +1 570 546 1253
andritz-fb.us@andritz.com

CHILE

p: +56 2 24624608
andritz-fb.cl@andritz.com

GERMANY

p: +49 2104 9197 0
andritz-fb.de@andritz.com

POLAND

p: +48 60 906 1037
andritz-fb.pl@andritz.com

VIETNAM

p: +84 8 6253 9434
andritz-fb.vi@andritz.com

ANDRITZ.COM/FT

ANDRITZ

All data, information, statements, photographs and graphic illustrations in this leaflet are without any obligation and raise no liabilities to or form part of any sales contracts of ANDRITZ AG or any affiliates for equipment and/or systems referred to herein. © ANDRITZ AG 2019. All rights reserved. No part of this copyrighted work may be reproduced, modified or distributed in any form or by any means, or stored in any database or retrieval system, without the prior written permission of ANDRITZ AG or its affiliates. Any such unauthorized use for any purpose is a violation of the relevant copyright laws. ANDRITZ AG, Stattegger Strasse 18, 8045 Graz, Austria.



3013 GB

B 1116