



BEST ACTIVATION OF NATURAL BINDERS

SHANGHAI CONDITIONER TYPE SCM AND SDDC

ANDRITZ

Best activation of natural binders

ANDRITZ has developed distinctive conditioner models designed to provide the best preparation of raw material prior to entering the pelleting or extrusion process. Conditioning is the most effective way of achieving excellent pellet quality. Using just the right combination of heat, moisture, and time, conditioning activates the naturally occurring binding components in plant materials and makes pelleting and extrusion easier and more efficient.

SCM CONDITIONER

The ANDRITZ SCM conditioner, manufactured in stainless steel, is characterized by a compact structure, low energy consumption, and a long working life. The machine adopts different structures for different kinds of feed, especially for shrimp feed. Extended conditioners and jacketed conditioners are optional, which helps to meet the different requirements, such as longer retention time, higher temperature, or both.

SCM conditioner



SDDC CONDITIONER

The ANDRITZ double-shaft conditioner is well suited for various kinds of materials. All parts coming in contact with feed are made of stainless steel for corrosion resistance and feed safety. It is equipped with two large-volume barrels for higher liquid addition as well bearings that are internationally recognized for their durability. A homogenous mix is achieved quickly and efficiently, thanks to the differential speed of the dual shafts.

SDDC conditioner



SCM CONDITIONER

Characterized by compact structure, low energy consumption and long working life.

SCM conditioner

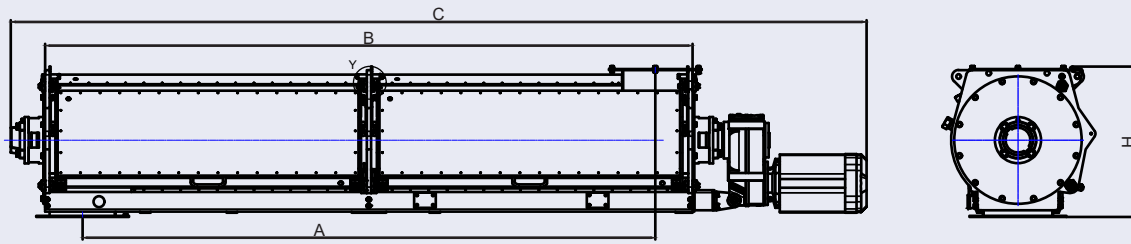

SDDC conditioner

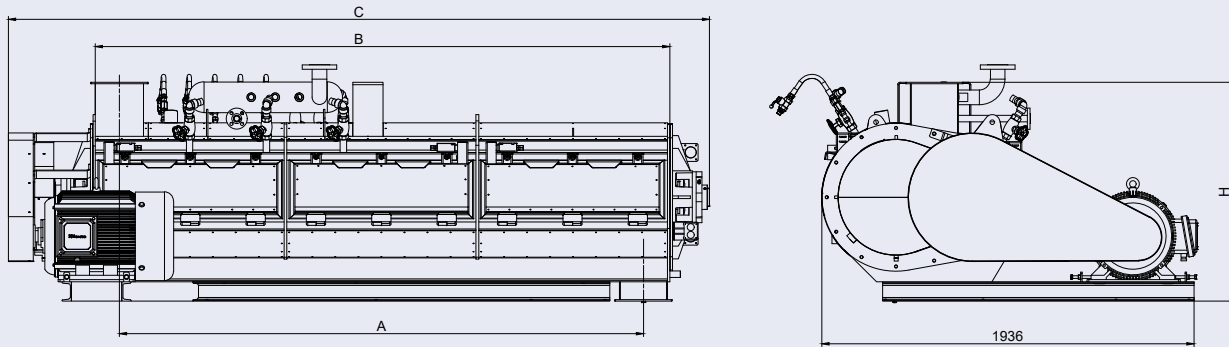

TECHNICAL SPECIFICATIONS

Model	Transmission	Dimensions	Motor power	Inlet size	Outlet size	Shaft speed
		mm	kW/HP	mm	mm	rpm
SCM300	Gearmotor	Ø400x2500	7.5/4P	260x200	260x200	250
SCM400	Gearmotor	Ø400x3000	11/4P	260x200	260x200	250
SCM500	Gearmotor	Ø500x2500	11/4P	320x300	320x300	250
SCM600	Gearmotor	Ø500x3000	11/4P	320x300	320x300	250
SDDC680	V Type Belt Open gear	Ø660/Ø520 x3000	22/8P	250x250	250x250	100/200

DIMENSION SIZE (MM)

Model	H	A	B	C
SCM300	615	2254	2500	3422
SCM400	615	2754	3000	3963
SCM500	700	2154	2500	3463
SCM600	700	2654	3000	3963
SDDC680	1138	2726	3000	3648

Optimum conditioning results in the desired activation of natural binders by using heat, moisture and time.



GLOBAL SUPPLIER – LOCAL PRESENCE

ANDRITZ Feed & Biofuel is truly a global organization – with local presence. We are represented all over the world. The global market is served from five main locations in Denmark, China, Netherlands, USA, and Slovakia.

In addition, ANDRITZ Feed & Biofuel operates from several strategic regional sales, engineering, and service locations in Australia, Bangladesh, Brazil, Canada, Chile, Dubai, France, Germany, India, Italy, Mexico, Poland, South Africa, Thailand, Turkey, the UK and Vietnam – and is also represented locally by agents and distributors in many other markets.

ANDRITZ Feed & Biofuel A/S

Glentevej 5–7
6705 Esbjerg, Denmark
p: +45 72 160 300
andritz-fb.dk@andritz.com

ANDRITZ (Shanghai) Equipment & Engineering Co., LTD

No.2288, Rongle East Road, Songjiang,
201613, Shanghai, P.R.China
p: +86 21 57745781
andritz-fb.cn@andritz.com

AUSTRALIA

ANDRITZ Feed & Biofuel
p: +61 3 8773 4888
andritz-fb.au@andritz.com

CHINA

ANDRITZ Feed & Biofuel
p: +86 21 5774 5781
andritz-fb.cn@andritz.com

ITALY

ANDRITZ Feed & Biofuel
p: +39 025 743 01 30
andritz-fb.it@andritz.com

THAILAND

ANDRITZ Feed & Biofuel
p: +66 2258 5528
andritz-fb.dk@andritz.com

BANGLADESH

ANDRITZ Feed & Biofuel
p: +880 22 222 64 800
andritz-fb.bd@andritz.com

DUBAI

ANDRITZ Feed & Biofuel
p: +971 4 214 6546
andritz-fb.uae@andritz.com

MEXICO

ANDRITZ Feed & Biofuel
p: +52 229 178 38 45
andritz-fb.mx@andritz.com

TURKEY

ANDRITZ Feed & Biofuel
p: +90 232 570 38 00
andritz-fb.tr@andritz.com

BRAZIL

ANDRITZ Feed & Biofuel
p: +55 47 3387 9146
andritz-fb.br@andritz.com

FRANCE

ANDRITZ Feed & Biofuel
p: +33 24 75 06 364
andritz-fb.fr@andritz.com

NETHERLANDS

ANDRITZ Feed & Biofuel
p: +31 40 262 7777
andritz-fb.nl@andritz.com

UK

ANDRITZ Feed & Biofuel
p: +44 1482 825 119
andritz-fb.uk@andritz.com

CANADA

ANDRITZ Feed & Biofuel
p: +1 519 676 7057
anbosales@andritz.com

GERMANY

ANDRITZ Feed & Biofuel
p: +49 2104 91970
andritz-fb.de@andritz.com

POLAND

ANDRITZ Feed & Biofuel
p: +48 60 906 1037
andritz-fb.pl@andritz.com

USA

ANDRITZ Feed & Biofuel
p: +1 570 546 1253
andritz-fb.us@andritz.com

CHILE

ANDRITZ Feed & Biofuel
p: +56 2 2246 24 600
andritz-fb.cl@andritz.com

INDIA

ANDRITZ Feed & Biofuel
p: +91 87544 15287
andritz-fb.india@andritz.com

SOUTH AFRICA

ANDRITZ Feed & Biofuel
p: +27 82 781 0808
andritz-fb.dk@andritz.com

VIETNAM

ANDRITZ Feed & Biofuel
p: +84 28 6253 9434
andritz-fb.vi@andritz.com



[ANDRITZ.COM/FT](https://www.andritz.com/ft)

All data, information, statements, photographs and graphic illustrations in this leaflet are without any obligation and raise no liabilities to or form part of any sales contracts of ANDRITZ AG or any affiliates for equipment and/or systems referred to herein. © ANDRITZ GROUP 2025. All rights reserved. No part of this copyrighted work may be reproduced, modified or distributed in any form or by any means, or stored in any database or retrieval system, without the prior written permission of ANDRITZ AG or its affiliates. Any such unauthorized use for any purpose is a violation of the relevant copyright laws. ANDRITZ AG, Stattegger Strasse 18, 8045 Graz, Austria.

