



# HIGH PERFORMANCE GRINDING

SHANGHAI HAMMER MILL TYPE SHM

**ANDRITZ**

# ANDRITZ hammer mill

## High performance grinding

ANDRITZ SHM series of hammer mills can be used in a wide range with large grinding ability, less vibration and low cost of maintenance.

The water drop-shaped grinding chamber and re-grinding room at the bottom, increases the efficiency. The chain clamp system ensures a quick and safe changing and is also suitable for various non-welding screens. Adjusting the air discharge system avoids blocking. The bi-directional rotor ensures the maximum usage of hard hammers. SKF main shaft bearings ensures it continuous free-trouble running.

### STANDARD FEATURES

- Wide range of outlet product in size
- High-speed operation
- Superior feed quality
- Reduced energy consumption
- Nutritive value of feed ingredients protected by low-temperature operation
- Reversible direction of rotation
- Temperature monitoring of bearing
- Directly coupled motor on the base frame

### FEEDER SYSTEM FOR EVEN MATERIAL DISTRIBUTION

Material feeding in full grinding chamber length to ensure uniform load on screens and hammers.

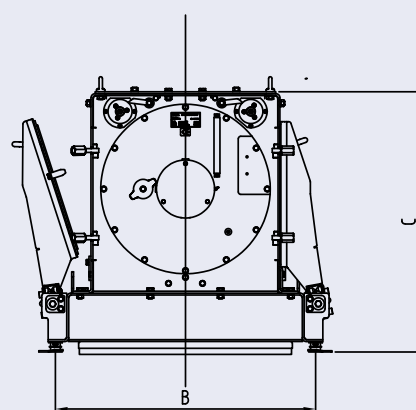
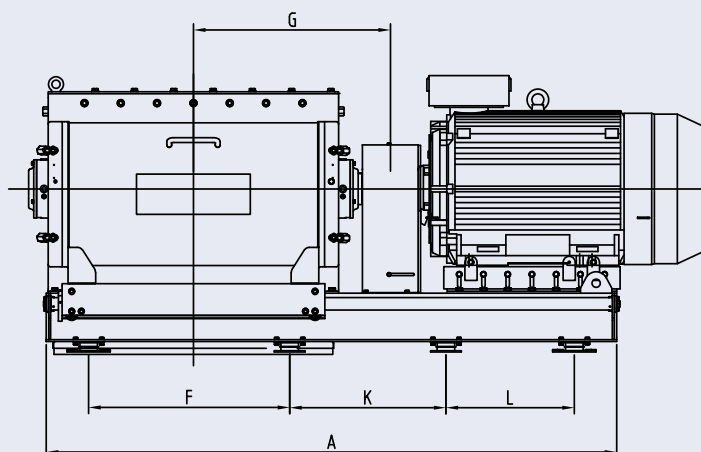

Dimensions in mm



# ANDRITZ SHM hammer mill present high-performance grinding in animal & aquatic feed and pet food production lines

## OPTIONAL FEATURES

- Grinding chamber temperature monitoring
- Rotor brake device

## ACCESSORIES

- Discharge bin and aspiration filter
- Operating platform and feeding system

## TECHNICAL DATA

Type	Motor power	Motor, 50/60 Hz	Screen area	Hammer	Air flow	Filter area	Filter type
SHM	kW	rpm	dm <sup>2</sup>	6mm	m <sup>3</sup> /h	m <sup>2</sup>	EFF WB
SHM80	90-160	3000/3600	106	116	5000	24	36/1800
SHM100	160-250	3000/3600	133	152	6300	33	48/1800

Model	Rotor diameter	Grinding room width	Main shaft speed	Main motor power	Capacity @corn	Number of hammers	Screen size	Assorted feeder model
SHM	mm	mm	rpm 50/60hz	kW	t/h		mm	
SHM80	650	800	3000/3600	90/110/132/160	10~12tph/Ø3 mm screen	116	808x710	SRF80
SHM100	650	1000	3000/3600	160/200/250	20~25tph/Ø3 mm screen	152	11035x710	SRF100/ DS250+ SEP10010

## DIMENSION SIZE (MM)

Type	Dimensions				inlet	Weights	Volume
	mm	rpm	dm <sup>2</sup>	6mm			
SHM	A	B	C	D	m <sup>3</sup> /h	m <sup>2</sup>	m <sup>3</sup>
SHM80	2125	3000/3600	106	116	5000	24	36/1800
SHM100	2355	3000/3600	133	152	6300	33	48/1800



## GLOBAL SUPPLIER – LOCAL PRESENCE

ANDRITZ Feed & Biofuel is truly a global organization – with local presence. We are represented all over the world. The global market is served from five main locations in Denmark, China, Netherlands, USA, and Slovakia.

In addition, ANDRITZ Feed & Biofuel operates from several strategic regional sales, engineering, and service locations in Australia, Bangladesh, Brazil, Canada, Chile, Dubai, France, Germany, India, Italy, Mexico, Poland, South Africa, Thailand, Turkey, the UK and Vietnam – and is also represented locally by agents and distributors in many other markets.

### ANDRITZ Feed & Biofuel A/S

Glentevej 5–7  
6705 Esbjerg, Denmark  
p: +45 72 160 300  
andritz-fb.dk@andritz.com

### ANDRITZ (Shanghai) Equipment & Engineering Co., LTD

No.2288, Rongle East Road, Songjiang,  
201613, Shanghai, P.R.China  
p: +86 21 57745781  
andritz-fb.cn@andritz.com

### AUSTRALIA

ANDRITZ Feed & Biofuel  
p: +61 3 8773 4888  
andritz-fb.au@andritz.com

### CHINA

ANDRITZ Feed & Biofuel  
p: +86 21 5774 5781  
andritz-fb.cn@andritz.com

### ITALY

ANDRITZ Feed & Biofuel  
p: +39 025 743 01 30  
andritz-fb.it@andritz.com

### THAILAND

ANDRITZ Feed & Biofuel  
p: +66 2258 5528  
andritz-fb.dk@andritz.com

### BANGLADESH

ANDRITZ Feed & Biofuel  
p: +880 22 222 64 800  
andritz-fb.bd@andritz.com

### DUBAI

ANDRITZ Feed & Biofuel  
p: +971 4 214 6546  
andritz-fb.uae@andritz.com

### MEXICO

ANDRITZ Feed & Biofuel  
p: +52 229 178 38 45  
andritz-fb.mx@andritz.com

### TURKEY

ANDRITZ Feed & Biofuel  
p: +90 232 570 38 00  
andritz-fb.tr@andritz.com

### BRAZIL

ANDRITZ Feed & Biofuel  
p: +55 47 3387 9146  
andritz-fb.br@andritz.com

### FRANCE

ANDRITZ Feed & Biofuel  
p: +33 24 75 06 364  
andritz-fb.fr@andritz.com

### NETHERLANDS

ANDRITZ Feed & Biofuel  
p: +31 40 262 7777  
andritz-fb.nl@andritz.com

### UK

ANDRITZ Feed & Biofuel  
p: +44 1482 825 119  
andritz-fb.uk@andritz.com

### CANADA

ANDRITZ Feed & Biofuel  
p: +1 519 676 7057  
anbosales@andritz.com

### GERMANY

ANDRITZ Feed & Biofuel  
p: +49 2104 91970  
andritz-fb.de@andritz.com

### POLAND

ANDRITZ Feed & Biofuel  
p: +48 60 906 1037  
andritz-fb.pl@andritz.com

### USA

ANDRITZ Feed & Biofuel  
p: +1 570 546 1253  
andritz-fb.us@andritz.com

### CHILE

ANDRITZ Feed & Biofuel  
p: +56 2 2246 24 600  
andritz-fb.cl@andritz.com

### INDIA

ANDRITZ Feed & Biofuel  
p: +91 87544 15287  
andritz-fb.india@andritz.com

### SOUTH AFRICA

ANDRITZ Feed & Biofuel  
p: +27 82 781 0808  
andritz-fb.dk@andritz.com

### VIETNAM

ANDRITZ Feed & Biofuel  
p: +84 28 6253 9434  
andritz-fb.vi@andritz.com



[ANDRITZ.COM/FT](https://www.andritz.com/ft)

All data, information, statements, photographs and graphic illustrations in this leaflet are without any obligation and raise no liabilities to or form part of any sales contracts of ANDRITZ AG or any affiliates for equipment and/or systems referred to herein. © ANDRITZ GROUP 2025. All rights reserved. No part of this copyrighted work may be reproduced, modified or distributed in any form or by any means, or stored in any database or retrieval system, without the prior written permission of ANDRITZ AG or its affiliates. Any such unauthorized use for any purpose is a violation of the relevant copyright laws. ANDRITZ AG, Stattegger Strasse 18, 8045 Graz, Austria.

