



PRESS FABRIC INSTALLATION SYSTEM

ANDRITZ Felt Master

ANDRITZ

ANDRITZ Felt Master

Operational performance and maximum paper machine availability is extremely important in paper making production. The efficient use of downtime and manpower is essential during a shutdown – and fabric changes put a demand on both.

ANDRITZ has developed a unique fabric installation device – ANDRITZ Felt Master. This felt changing system is available for both seam and endless felts. An essential goal of this development was to significantly improve worker safety as well as to improve resource management. In addition, ease of handling and more uniform pulling-in of the fabric were key targets so that production can be resumed in the shortest possible time. With the help of the ANDRITZ Felt Master during clothing changes, resources can be better planned, and downtimes optimized.

BENEFITS

- Increased work safety
- Optimization of downtime
- Ease of use
- Improved resource management

CONTROL VIA REMOTE CONTROL DEVICE

The ANDRITZ Felt Master is operated via a remote-control device. The operator manages the speed during the installation with the help of a variable-speed control unit. For additional feedback and control, the motor and gearbox torque are monitored and displayed on the remote-control device. Special attention has been paid to designing low-maintenance equipment.



Remote control device

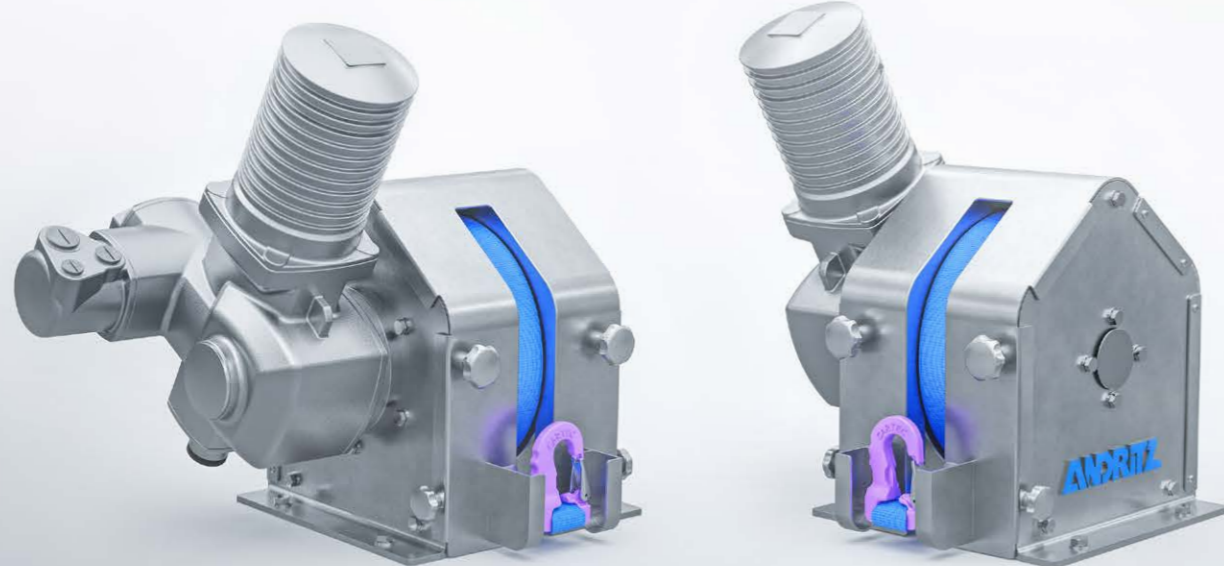

ANDRITZ Felt Master

PULLING-ON SEAM FELTS

With the aid of the Felt Master, a seam felt can be semi-automatically pulled full width from the packaging tube into the paper machine. The packaging tube containing the new felt is supported on two consoles, where the unwinding can be controlled by means of a mechanical brake. The installation “kite” of the new felt is then attached to the belt of the unwinding unit and pulled to the final position for seaming.

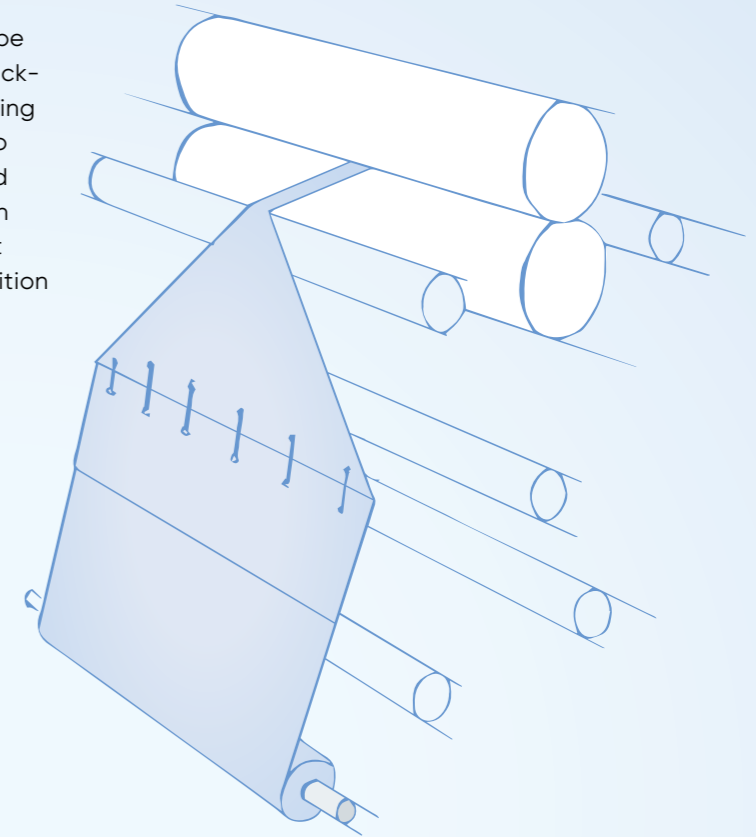

PULLING-IN ENDLESS FELTS

The new clothing must be fully laid out in front of the machine to ensure that it can be properly pulled in smoothly. The new clothing is aligned parallel to the machine where fasteners of the installation belts are attached to the felt at predefined positions. The installation belts are then tensioned to ensure even feeding. The operating personnel can monitor and control the speed and tension via the control unit. The ANDRITZ Felt Master is quite flexible and can be configured with up to 6 installation aids.

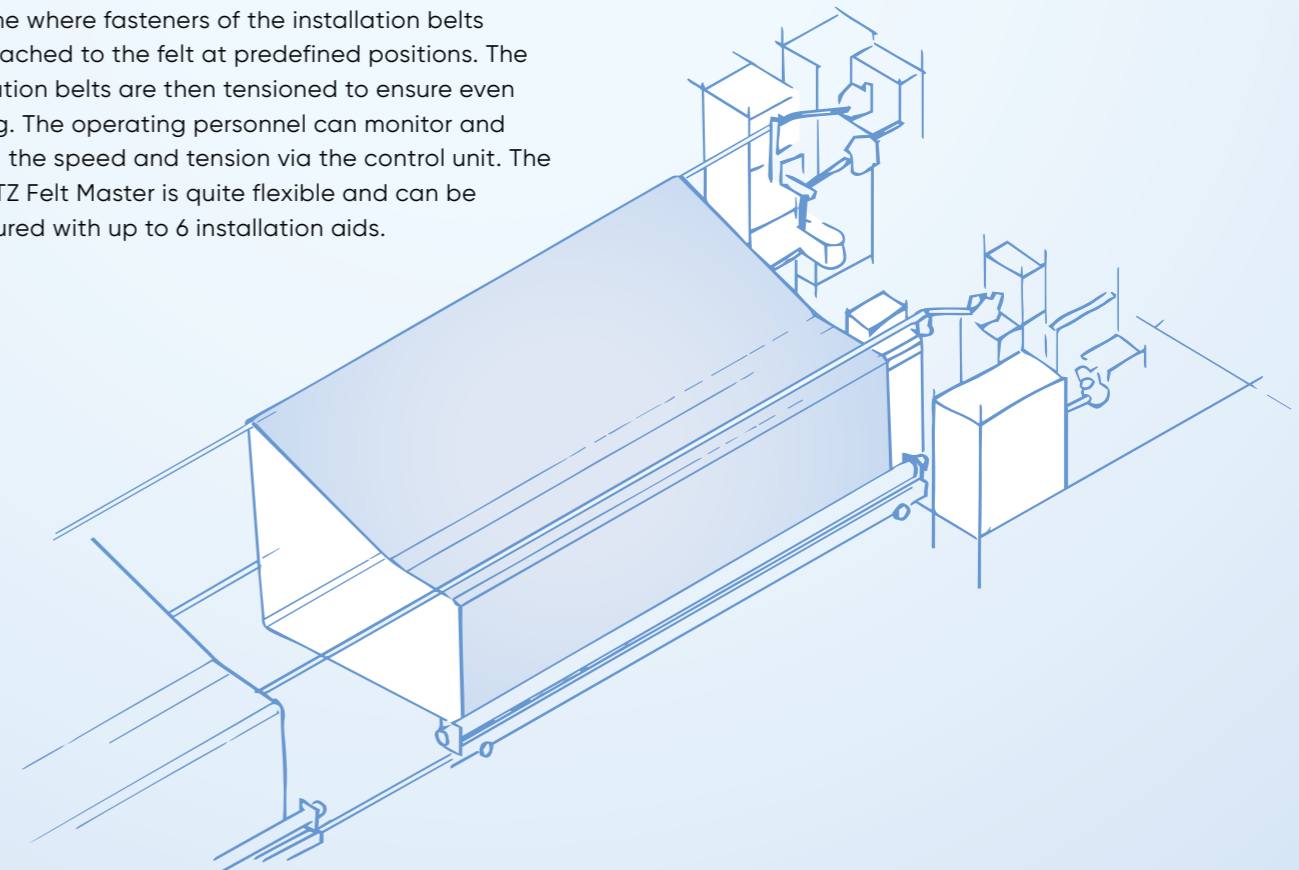



PrimeService FOR TISSUE, PAPER AND BOARD: IMPROVE YOUR MACHINE PERFORMANCE

ANDRITZ supplies spare parts and engineered wear products and provides customer-specific maintenance and upgrade services for your paper mill –from stock preparation to the winder, including automation solutions, and pumps.

Our service specialists are skilled and experienced at raising the production efficiency of a machine, process step, or production line. Their knowledge helps protect and extend the life of your equipment and lower your overall operating costs. The huge variety of ANDRITZ upgrade products provides performance improvements, energy and cost savings as well as return on investment (ROI) within shortest time. We work closely with you to monitor, maintain, repair, and upgrade your assets. Full support – technically, mechanically, and personally – is provided to you regard-less of who originally manufactured your equipment.

EUROPE

ANDRITZ AG
Graz, Österreich
p: +43 316 6902 2711

CHINA

ANDRITZ (CHINA) LTD.
Foshan, Guangdong, China
p: +86 757 8296 9222

NORTH AMERICA

ANDRITZ Inc.
Springfield, MA, USA
p: +1 413 750 4600

SOUTH AMERICA

ANDRITZ BRASIL LTDA.
Curitiba, Brazil
p: +55 41 2103 7601

ANDRITZ.COM/PRIMESERVICE

papermachine-service@andritz.com



All data, information, statements, photographs and graphic illustrations in this brochure are without any obligation and raise no liabilities to or form part of any sales contracts of ANDRITZ AG or any affiliates for equipment and/or systems referred to herein. © ANDRITZ Group 2026. All rights reserved. No part of this copyrighted work may be reproduced, modified or distributed in any form or by any means, or stored in any database or retrieval system, without the prior written permission of ANDRITZ AG or its affiliates. Any such unauthorized use for any purpose is a violation of the relevant copyright laws. Due to legal requirements, we must inform you that ANDRITZ AG processes your data for the purposes informing you about the ANDRITZ Group and its activities. Find out more details about our data privacy declaration and your rights under the data protection legislation on our website: andritz.com/privacy. ANDRITZ AG, Stattegger Strasse 18, 8045 Graz, Austria. Papermachine-Service-Brochure Felt Master 1.2/01.2026 EN