



CREATE VALUE WITH MECHANICAL RECYCLING

Driving the circular economy

ANDRITZ



A DIVERSITY OF RAW MATERIALS TO PROCESS

- Post-consumer clothes
- Post-consumer mattresses
- Waste from spinning industry
- Post-industrial textile waste
- Pre/post-consumer textile waste
- Post-industrial carpet waste
- Pre/post-consumer carpet waste
- Pre/post-consumer mattresses
- And more ...



VARIOUS APPLICATIONS

- Automotive
- Bedding & furniture
- Building insulation
- Carpet underlay
- Hygiene
- Knitted
- Technical nonwovens
- Woven



CONTENTS

Benefit from turnkey solutions	4
Develop your products in our technical center	6
CETI (European Center for Innovative Textiles)	7
Dedicated service	8
Foresee digitally with Metris	10
Start with sorting textile waste	12
Take the proven route with mechanical recycling	13
Cotton soft waste recycling	14
Post-industrial waste for respinning	16
Post-consumer waste for respinning	17
Post-industrial waste for nonwovens	18
Post-consumer waste for nonwovens	19
Mechanical recycling machines and equipment	20
Cadette tearing machine	21
Exel tearing machine	22
Jumbo tearing machine	23
Picker shredder	24
Cutting system	25
Blending box	26
Controls and accessories	27



Benefit from turnkey solutions

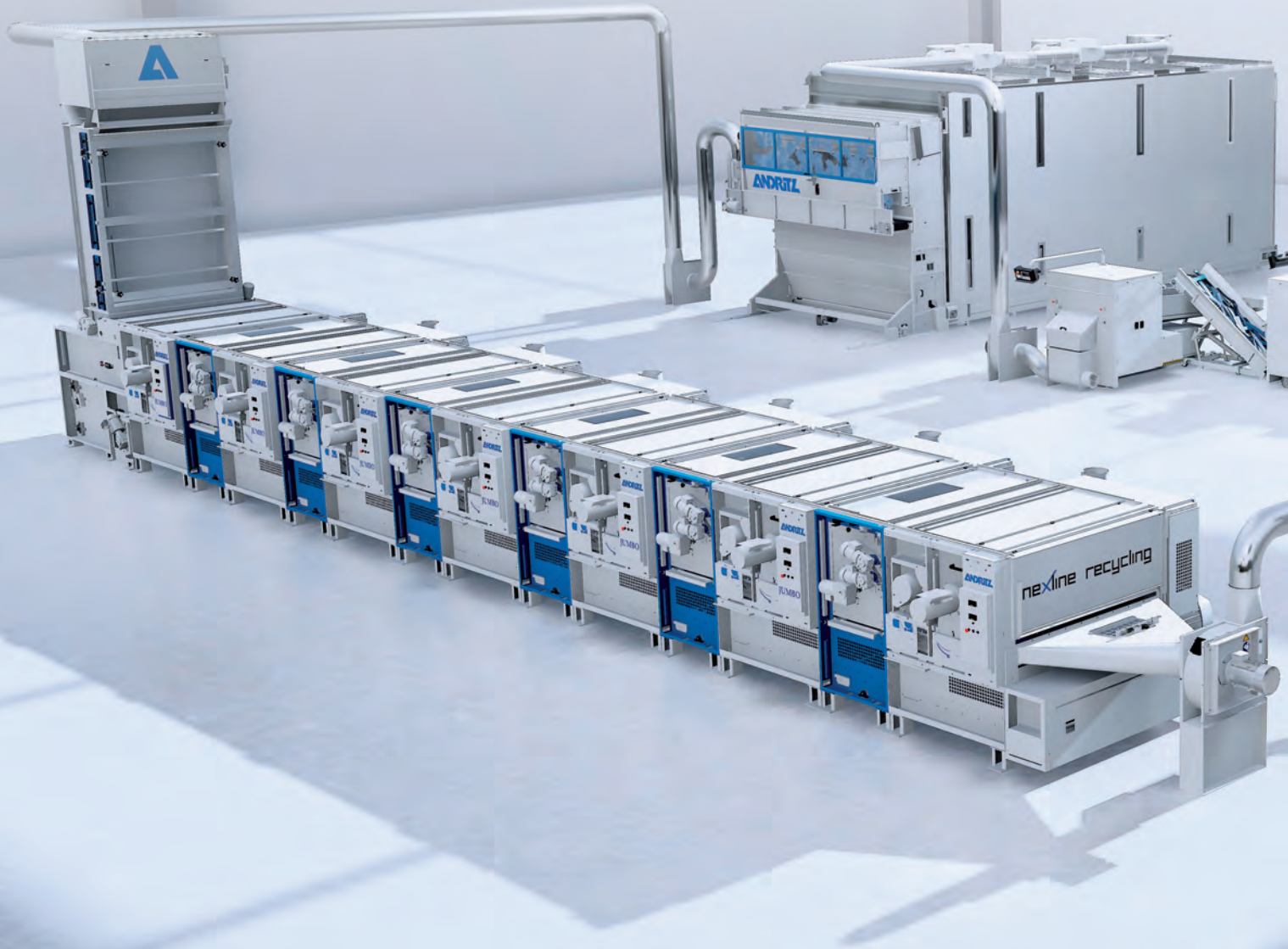

TEXTILE RECYCLING – A KEY TOPIC

Recycling at the highest level is one of the central topics for the next decade. Governments and the media are reminding us daily of the need to preserve our environment and natural resources. In the textile sector, the pressure is growing due to the unabated demand for resources. Today, clothing is over-supplied and much of it ends up incinerated or in landfill.

FULL SUITE IN TEXTILE RECYCLING PROCESSES

ANDRITZ has always been a pioneer in providing industrially and economically viable solutions that bring the circular economy to the world of textile fibers. ANDRITZ is not only a reliable supplier but also a knowledge provider. From textile sorting, textile fiber preparation to mechanical and chemical recycling and combined processes, we offer the full suite.





TAILOR-MADE SOLUTIONS

In order to provide the best end-product possible, we offer the opportunity to test and verify all the technical solutions developed at industrial scale. Our expertise in textile recycling gives us a 360° view of the technologies related to textile recycling as well as how the fiber is used after the process, on the nonwovens market as well as on the spinning market.

LEARN MORE ABOUT ALL OUR TEXTILE RECYCLING SOLUTIONS

From textile sorting, textile fiber preparation, to mechanical and chemical recycling processes



Develop your products in our technical center

A high level of expertise to fit your needs: Our technical center allow you to test and prove technical solutions on industrial lines and to get the most out of your investment with the support of highly skilled engineers. You can benefit from more than a century of expertise.

EXPERIENCE NEW PRODUCTS

We offer you the chance to test our tearing process. Benefit from our expertise and create opportunities to reinforce your market or to access or create new ones.

RESEARCH AND DEVELOPMENT

We continuously make new developments to improve our machines in all aspects such as safety, energy saving etc. We also provide a consistent development of new solutions for new textile articles and raw materials entering the market.

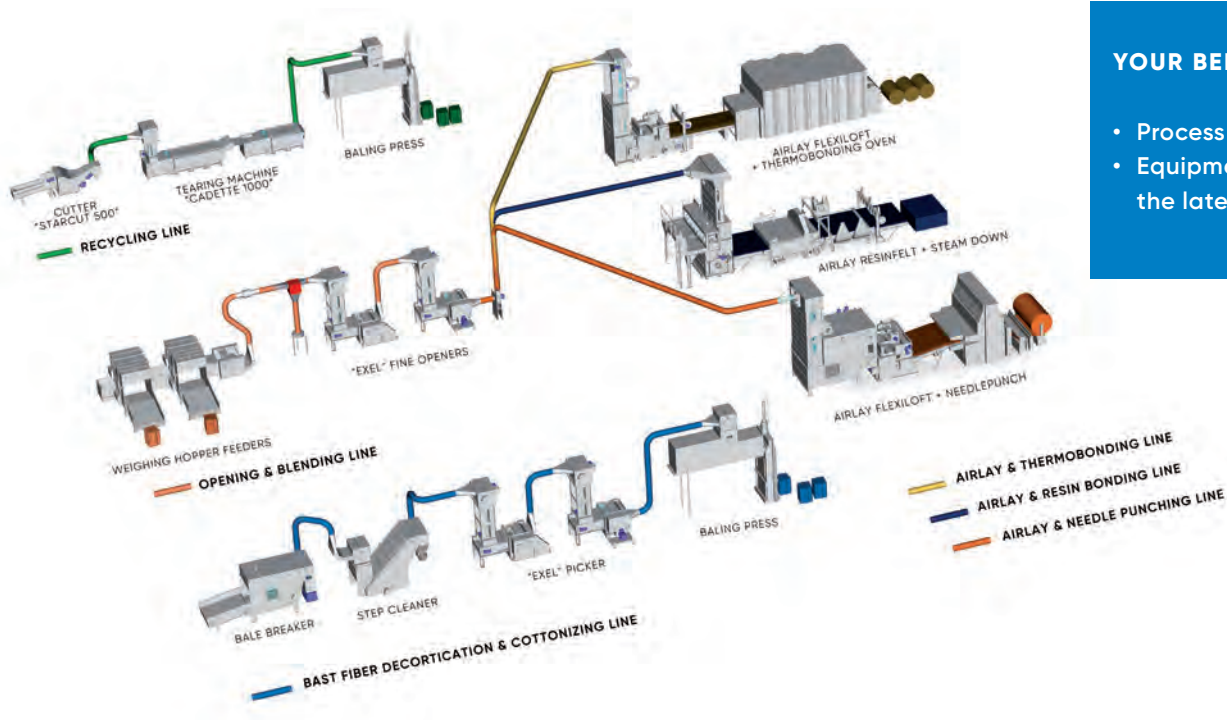

YOUR BENEFITS

- Process expert support
- Equipment containing the latest technology



ANDRITZ technical center in Cours, France



CETI (European Center for Innovative Textiles)

Discover an innovative platform for your trials: CETI is a unique collaborative space spanning 4,000 square meters in Tourcoing, France, dedicated to creativity, engineering, and prototyping.

With a decade of experience in the drylaid fibers transformation and in mechanical recycling processes, the CETI team closely works with their customers to deliver specific requirements and lay foundations for a more sustainable textile industry.

The CETI platform is equipped with ANDRITZ units such as preparation, blending for spinning, complete airlay and carding lines to carry out pilot and semi-industrial tests in the prototyping phase in order to transfer the optimal solutions at industrial scale.



Fibers blending and opening



Tearing machine



Carding and drawing



Carding



Airlay machine



Rotor spinning



Thermobonding process



Needling unit

CONTACT DETAILS:

CETI
41 rue des Métissages
59200 Tourcoing - France

DISCOVER THE WEBSITE
CETI, R&D platform



Dedicated service

We know how important uptime is for your production efficiency: That's why we do everything to keep interruptions to a minimum. With remote maintenance and a highly responsive service team, we can react to your issues in the shortest time possible.

SPARE PARTS

To ensure the longevity and the performance of your equipment, we recommend using only original spare parts from ANDRITZ. Our sales team for spare parts is at your disposal to help you choose the right parts.

UPGRADES AND RETROFITS

Our specialists are available to inspect your production lines and propose improvements to extend the product life of your equipment and increase productivity.

SKILLED TECHNICIANS AT YOUR DISPOSAL

With the goal of providing the most efficient and responsive service as possible, we assign a dedicated team of skilled technicians as well as automation and textile engineers.

ONLINE SUPPORT

We want to support you at all times. You always have a competent partner to explain any problems related to textile, mechanical, or electrical/electronic issues.



YOUR BENEFITS

- Service centers around the globe
- Technical and electrical diagnosis by experts
- Complete stock of original parts
- Assistance with installation, operation, maintenance, and training
- Improve your production operations
- Enhance the performance of your equipment



Foresee digitally with Metris

Industrial Internet of Things (IoT), Industry 4.0, digitalization – current buzzwords that industries use when seeking to improve their performance and equip themselves for the future of industry.



ANDRITZ DIGITAL SOLUTIONS

As a technology leader with extensive and long-term experience in supplying industrial measurement, control, and optimization solutions for various industries, ANDRITZ is combining process and equipment expertise with the latest enhancements in the digital era. The result of this powerful combination is Metris: a portfolio of ANDRITZ Digital Solutions.

METRIS OPP

One of the flagship capabilities of the Metris assortment is its ability to optimize industrial processes with Metris OPP. It has been developed over the past decade within the pulp and paper sector and has been introduced to the nonwovens industry. It combines powerful analytical and data mining software with the knowledge of the world's top process experts to deliver a smart service initiative for customers.





A CONSTANTLY GROWING PORTFOLIO

The depth and effectiveness of the Metris portfolio continues to improve thanks to ongoing R&D, collaboration with key customers and institutions, and venture activities. Portfolio options all rely on the three strategic focus areas of the Metris brand:

Industrial IoT technologies, Smart Service concepts, and Venture activities. The main technological advancements integrated into individual Metris products are derived from big data analytics, smart sensor technologies, and augmented reality solutions. The Metris UX platform providing full support throughout the entire

lifecycle of a plant is the most recent of our IoT developments. With Metris solutions, customers foresee digitally due to the continuously improved portfolio and its performance - and thanks to ANDRITZ providing tailored and fully integrated digital solutions from a single source.

Benefits

Metris - ANDRITZ Digital Solutions

- **IIoT solutions across business segments**
- **Combined know-how from ten years' experience with Metris OPP**
- **Using the latest smart sensor technologies**
- **Big data analysis with tried-and-tested models for deviation analysis**
- **Providing information locally with augmented reality**
- **Extensive solution and process engineering knowledge**
- **Cyber security solution to safeguard data on the network**

Start with sorting textile waste

Sorting textile waste is one of the most important pillars to optimize the quality of recycled fibers. It is a bottleneck and an essential part of the recycling value chain. Automation of this process represents a clear added value for the entire process.

THE AUTOMATED SORTING PROCESS

Innovative automated sorting makes it possible to separate parts of clothes by color and/or raw material. During this automated process, hard points are removed via tearing to obtain a material ready for mechanical recycling. We offer a wide range of tearing machines, which are suitable for many applications, for both spinning and nonwovens markets.

COLLABORATION LEADS TO SUCCESS

The unique process for automated sorting is the result of a long-term collaboration between ANDRITZ, Nouvelles Fibres Textiles, and Pellenc ST, France. Combining decades of expertise and know-how in sorting technologies by Pellenc ST, post-consumer

textile value chains from sorting to manufacturing by Nouvelles Fibres Textiles, and textile machinery and processes by ANDRITZ, we succeeded in finding the best solution for the huge challenge of textile sorting.

ANDRITZ and Nouvelles Fibres Textiles launched the project of the very first industrial line in France dedicated to textile sorting using a closed-loop process. These new opportunities provided by Nouvelles Fibres Textiles allows us to promote on-the-ground circularity for textiles in order to guarantee the traceability of recycled materials while reducing the environmental impact and carbon footprint of the textile industry.



Take the proven route with mechanical recycling

Attractive and feasible mechanical recycling solutions for pre- and post-consumer textile waste: Thanks to the mechanical tearing process developed by ANDRITZ Laroche for over a century and with more than 2,000 reference projects worldwide, you can process almost all types of pre/post-consumer textile waste.

Mechanical recycling by means of tearing aims to maintain the nature of the original fibers by maximizing fiber length and strength, for example with cotton. Today, Ne24 and Ne30 yarn counts use 70% recycled cotton fibers in some blends. The mechanical recycling process saves energy, uses less water and fewer chemicals, and enables a reduced machinery installation footprint.

The process offers a wide range of opportunities with many potential applications. Indeed, this mechanical technique makes it possible to obtain a high-quality fiber for both spinning and nonwoven industries. One of the benefits of mechanical recycling is its complementarity with airlay technology, especially designed for the production of nonwovens for the automotive, insulation, and bedding industries, among others.

YOUR BENEFITS

- Market development pioneers
- High-level expertise to assess the recyclability of customers' end-products

RECYCLING PROCESS ON THE BASIS OF MECHANICAL RECYCLING

Processing of textile waste for production of nonwoven products and yarn.

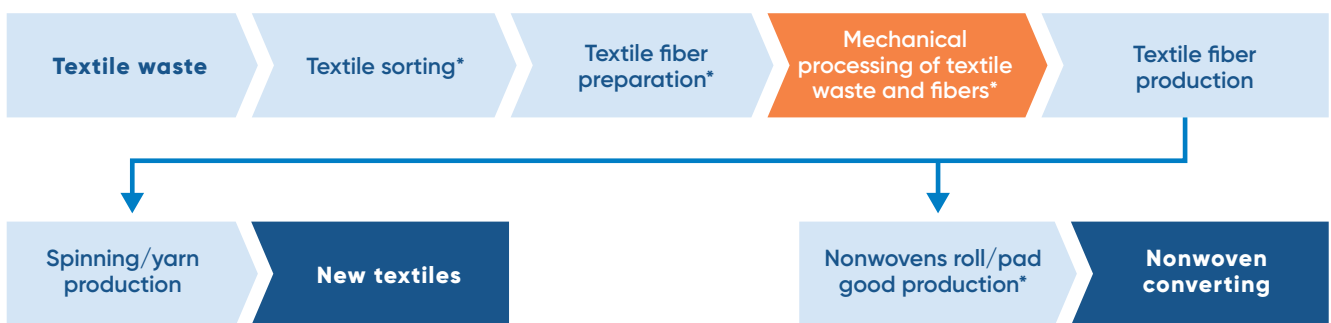

*Technology within ANDRITZ textile recycling portfolio

DISCOVER OUR PODCAST

Textile recycling is becoming all the rage, but what is it exactly? And what are the challenges and opportunities in this exciting sector?



Cotton soft waste recycling

Customized process: We offer cotton waste opening and cleaning lines for blowroom waste equipped with a modular design also for high production capacity and fiber yield. We also provide cleaning lines for gin notes, linters, and more. Potential applications include respinning, security paper, cardboard, tooth paste, and other cellulosic fiber applications.



Gin notes



Pre-cleaned



Cleaned open fiber

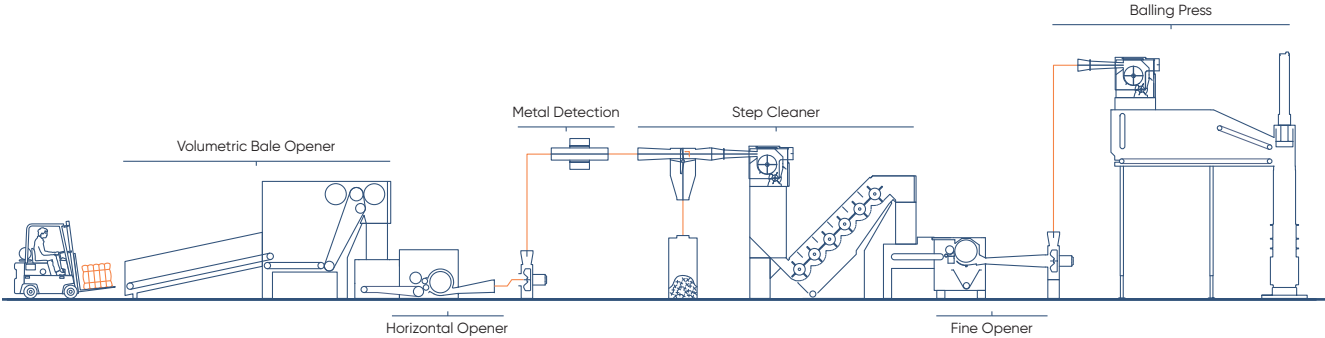



Post-industrial waste for respinning

Maximized fiber quality: Thanks to a gentle and progressive opening, our lines are able to process industrial waste for respinning purposes by offering a high-quality fiber in terms of length with low neps and unopened yarn contents.

We can achieve a high production output for spinning up to 1,000 kg/h*. Line examples are shown below.

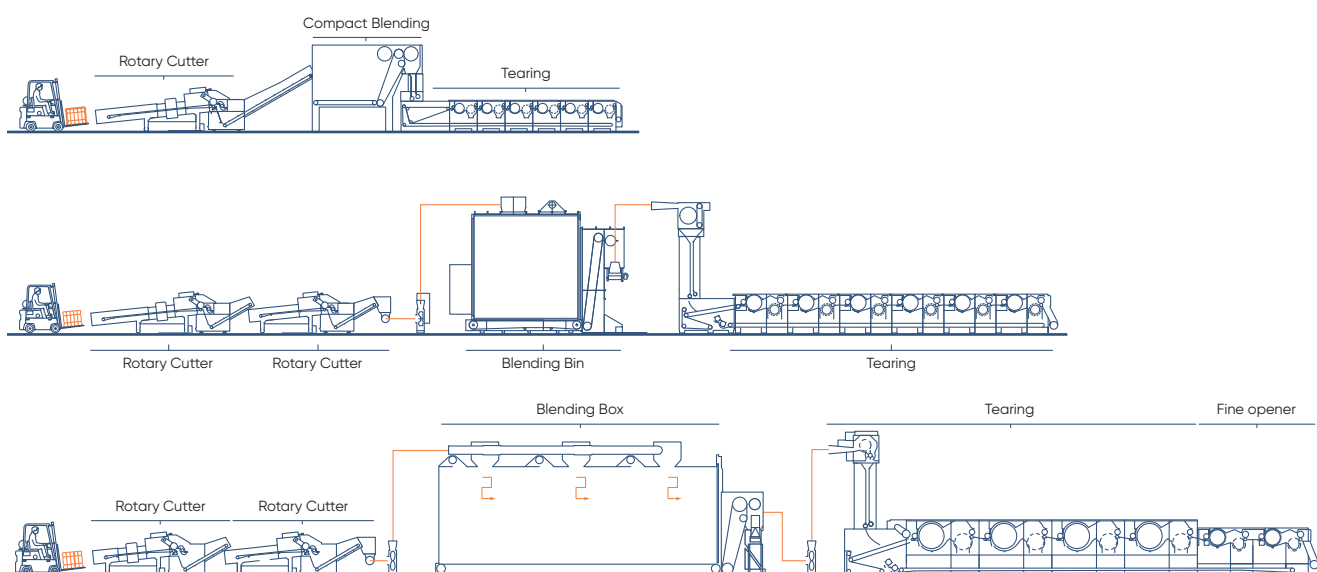

*Depending on input, raw material quality, and type of yarn to be made.



Exel tearing machines in operation



Post-consumer waste for respinning

Innovative process: We provide a complete innovative recycling line for converting clothing into regenerated fibers.

Our tearing machines, Exel and Jumbo, are specially designed to process post-consumer waste for the spinning industry. These units are able to provide a high-quality fiber thanks to a tailor-made automated system that removes the non-textile parts (hard points) from post-consumer waste and unsold items.

Our mechanical recycling lines enable you to achieve your sustainability goals and help to promote the circular economy by turning textiles into textiles, thus closing the loop of consumption.

YOUR BENEFITS

- High fiber length and strength
- Low machinery footprint
- High output capacity



Post-consumer recycling line for respinning in operation

Post-industrial waste for nonwovens

Ideal for airlay process: Our tearing lines for post-industrial waste recycling are completely adapted to obtain regenerated fibers for nonwovens.

These lines are ideal for our airlay and carding lines and enable fiber processing for a wide range of different nonwoven applications such as bedding, furniture, insulation, and automotive or carpet underlay.



YOUR BENEFITS

- Gentle and progressive opening to maximize fiber quality
- Fiber length
- Low neps content
- Low unopened yarn content
- High production outputs for spinning, up to 1,000 kg/h

Post-consumer waste for nonwovens

An efficient cleaning process: Our tearing lines offer complete recycling solutions for pre/post-consumer waste with a tailor-made automated system for removing non-textile parts.

These tearing lines perfectly fit the airlay process, providing a high-quality nonwoven fiber.



YOUR BENEFITS

- User-friendly operation
- Tailor-made automated solutions to remove non-textile parts (hard points)

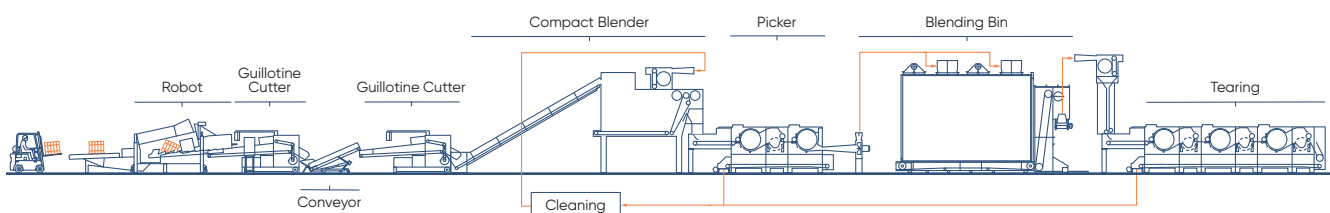

Mechanical recycling machines and equipment

The full range of solutions: Today, we offers a complete process range of tearing equipment, from 50 to 3,000 kg/h, applicable to a large variety of textile materials, natural, animal, synthetic, artificial, and mineral fibers.

ANDRITZ is at the core of the movement to provide industrially and economically viable solutions that bring circularity to the world of natural and synthetic fibers.

In order to improve the circular economy driven by our customers, we offer a large range of tearing machines and equipment designed for recycling both small and large volumes of textile products.

OUR PORTFOLIO:

Type of opener	Cadette	Exel	Jumbo
Working width	0.5 to 1 m	1 to 2 m	1.5 to 2 m
Capacity	50 to 150 kg/h*	100 to 1,500 kg/h*	700 to 3,000 kg/h*
Accessories	- Sharpener - Fiber lubrication	- Sharpener - Fiber lubrication	- Sharpener - Fiber lubrication
Options		Beater rollers cleaning device	Beater rollers cleaning device

*For nonwoven applications and depending on raw material quality.
For respinning applications, please contact us.



Cadette tearing machine

A tearing machine for in-house recycling: The ANDRITZ Cadette tearing machine has been specially designed for in-house recycling at technical and R&D centers.

The machine is designed to recycle spinning, weaving, knitting, and drylaid nonwoven wastes.

The Cadette machine can process all types of textiles raw materials, thanks to its opening cylinder of 350 mm.

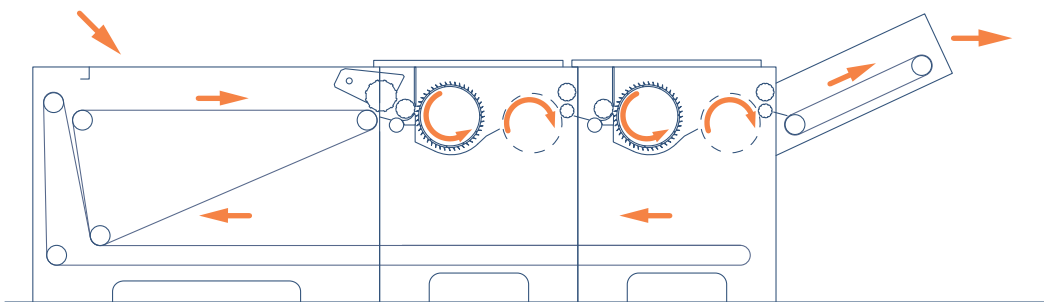

Cadette tearing unit for in-house recycling

WATCH THE VIDEO

Trials organized for Les Tissages de Charlieu and INDISPENSAC companies at ANDRITZ Laroche Technical Center



Exel tearing machine

A medium-range machine: The ANDRITZ Exel tearing machine is a medium-range machine specially adapted for spinning quality and equipped with a 600 mm diameter opening cylinder.

Designed for the recycling of all hard textile waste for optimized fiber quality, the Exel machine can be equipped with one to seven opening sections with

a working width of up to 2 m. The Exel module has adjustable setting while running in order to provide more flexibility during production.

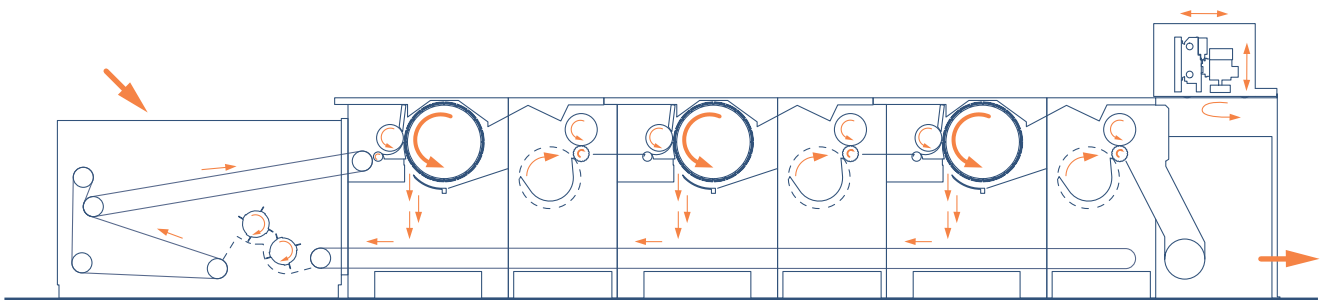

Exel tearing machine for medium-range capacities

Jumbo tearing machine

State-of-the-art machine for high-production capacity: The ANDRITZ Jumbo tearing machine has been specially designed to process all types of textile waste. This machine can be equipped with one to seven opening sections with a working width of 1.5 to 2 m.

This machine is available can be combined with Exel fine opener modules for a better fiber opening. The Jumbo machine has adjustable settings while running

in order to provide more flexibility during production. adjustable setting while running in order to provide more flexibility during production.

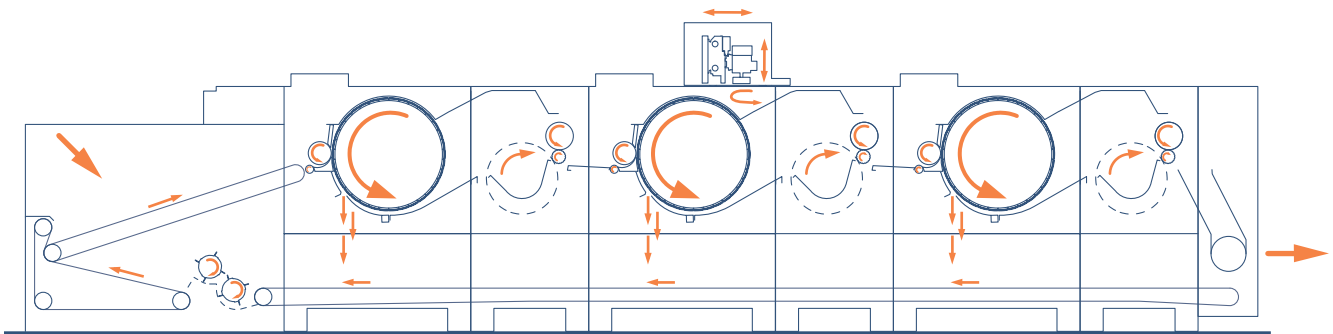

Jumbo tearing module for high-production capacities

Picker shredder

For ideal pre-opening and cleaning: The picker shredder machine is specially designed for old rags, carpets, and moulding wastes.

On the picker, we can adjust settings while the machine is running.

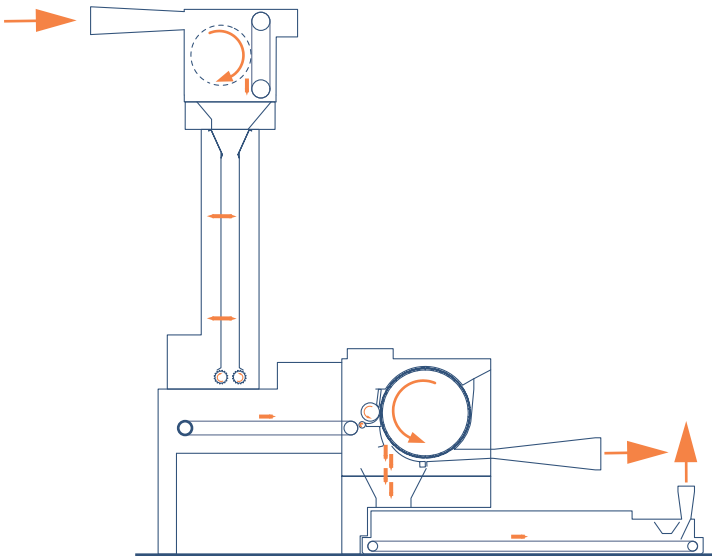

Picker shredder for pre-opening and cleaning

Cutting system

For an accurate and flexible cutting process: Our solutions range from simple systems with one or two rotary cutters to complete cutting plants.

The Starcut rotary cutter is equipped with a cutting head with two or four flying knives and a feeding conveyor rolling out of the machine for easy access.

This machine is also equipped with a built-in sharpener. We also optionally provide a metal detector and a dedusting system for the cutting head.

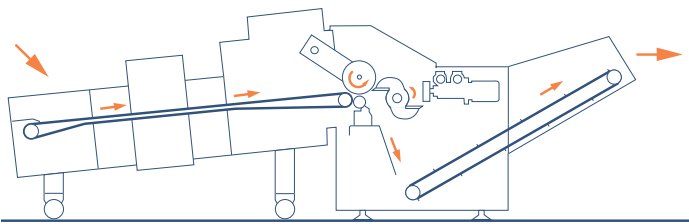

Starcut rotary cutter

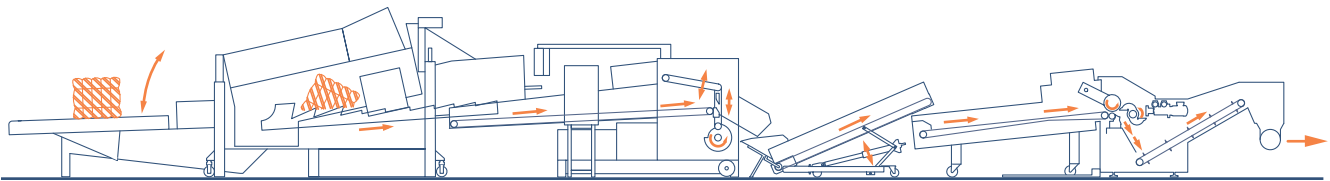

Robot feeder, CT60 and Starcut rotary cutter



Guillotine and Starcut rotary cutter

Blending box

Guaranteeing blend homogeneity: In order to ensure long-term blend consistency, we provide a wide range of blending boxes with a working width of 3 to 3.9 m and a storage capacity of 35 to 300 m³.

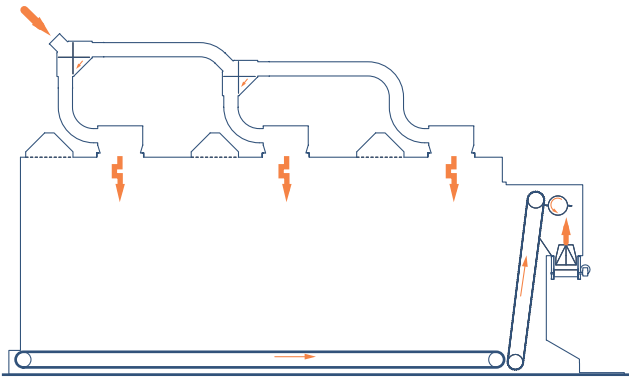

Blending box for optimal fiber blend homogeneity

Controls and accessories

METAL DETECTION

Our tearing lines are also available with a highly sensitive metal detection device and automatic rejection of contaminated materials, which can be combined with fire detection system. The metal detector ensures the total absence of metallic material in the raw material.

FIBER LUBRICATION SYSTEM

The lubrication of the fibers is based on a compact system with a reserve tank, dosing pump, and atomizers. The lubrication helps prevent static electricity during textile waste recycling, thus reducing damage and improving fiber characteristics.

BALING SYSTEM

We offer a full range of fiber baling systems, from single and double boxes with a pressure of 100 up to 200 tons.

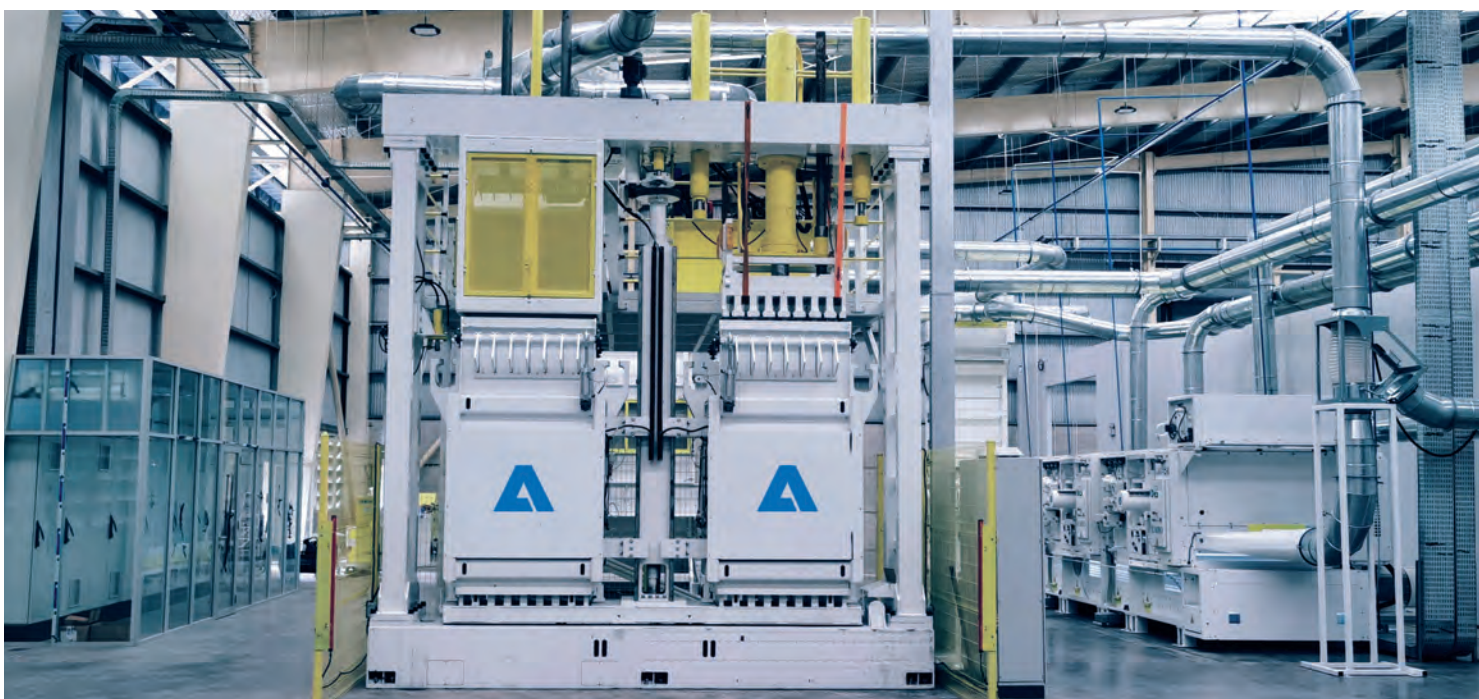
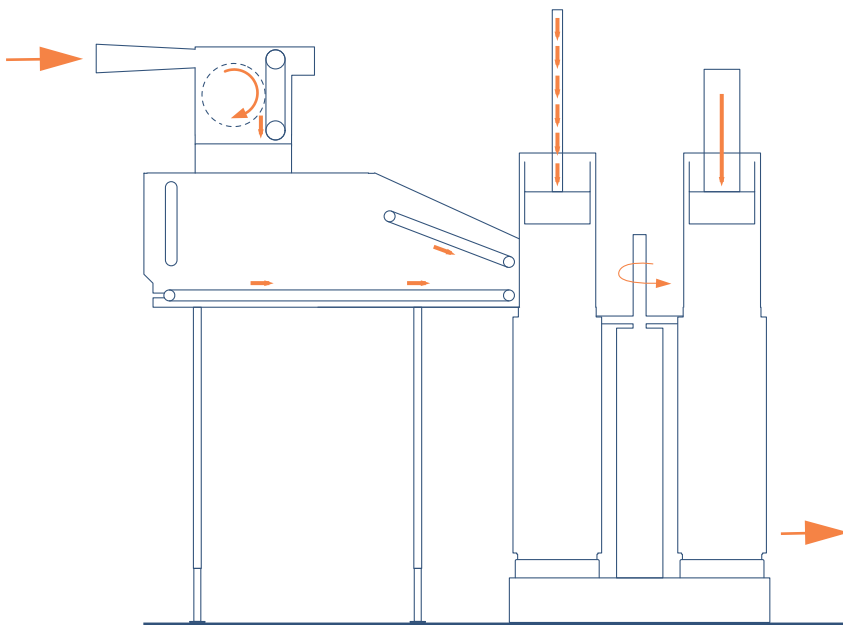

Baling system for fiber baling

GET THE MOST OUT OF YOUR INVESTMENT

At ANDRITZ Nonwoven and Textile we know that your business depends on satisfied customers and efficient processes. That's why we support you in every aspect of your nonwoven and textile production. Take advantage of technology that lets you produce consistent quality for decades to come. Profit from the highly efficient use of energy and raw materials that our production provides. You can rely on our responsive service teams who will protect your investment and optimize your processes. Experience how innovative approaches and digital services give you more control than ever before. With ANDRITZ, the leading supplier for the nonwoven and textile market, you get the most out of your investment.

FRANCE

ANDRITZ Laroche SAS
Cours-la-ville, France
p: +33 4 74 89 84 85
laroche@andritz.com

ANDRITZ FRANCE SAS
Elbeuf, France
p: +33 2 32 96 42 42
andritz-france@andritz.com

GERMANY

ANDRITZ Küsters GmbH
Krefeld, Germany
p: +49 2151 34 0
kuesters@andritz.com

ITALY

ANDRITZ Diatec Srl
Collecorvino, Italy
p: +39 085 82060-1
diatec@andritz.com

DENMARK

ANDRITZ Dan-Web A/S
Galten, Denmark
p: +45 87 43 95 00

AUSTRIA

ANDRITZ AG
Graz, Austria
p: +43 316 690 20
recycling@andritz.com

FINLAND

ANDRITZ Oy
Kotka, Finland
p: +358 020 450 5555
fiberline@andritz.com

CHINA

ANDRITZ (China) Ltd.
Wuxi, P.R. China
p: +86 510 8536 1269
nonwoven-china@andritz.com

INDIA

ANDRITZ Technologies Pvt. Ltd.
Chennai, India
p: +91 44 4293 9393
nonwovenservice.india@andritz.com

USA

ANDRITZ Inc.
Spartanburg, USA
p: +1 864 587 4848
nonwoven-americas@andritz.com

[ANDRITZ.COM/MECHANICAL-RECYCLING](https://www.andritz.com/mechanical-recycling)

JOIN US ON SOCIAL MEDIA



ANDRITZ

All data, information, statements, photographs and graphic illustrations in this leaflet are without any obligation and raise no liabilities to or form part of any sales contracts of ANDRITZ AG or any affiliates for equipment and/or systems referred to herein. Picture page 17 by courtesy of Robin Inizan, Lucas Pavy Production - Renaissance textile. © ANDRITZ AG 2023. All rights reserved. No part of this copyrighted work may be reproduced, modified or distributed in any form or by any means, or stored in any database or retrieval system, without the prior written permission of ANDRITZ AG or its affiliates. Any such unauthorized use for any purpose is a violation of the relevant copyright laws. ANDRITZ AG, Stattegger Strasse 18, 8045 Graz, Austria. Mechanical recycling brochure 1.0/08.2023 EN.

