

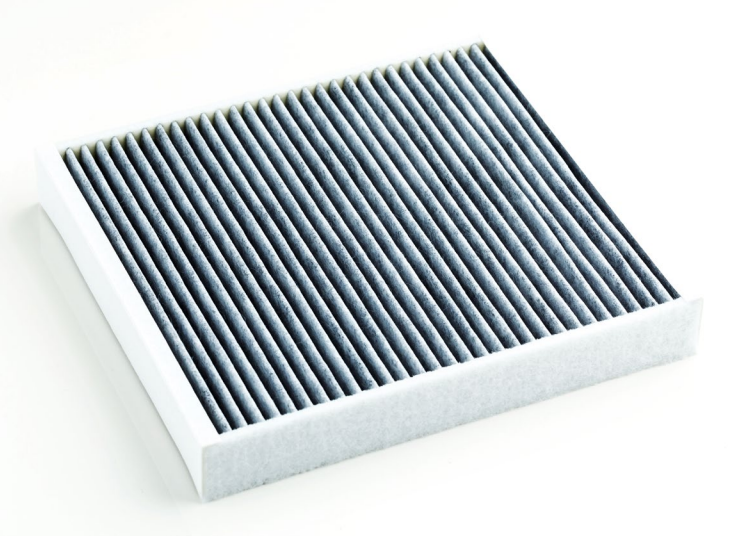

NONWOVEN
**BE INNOVATIVE
WITH AIRLAY**

FOR YEARS TO COME

ANDRITZ



VARIOUS APPLICATIONS

- Automotive
- Bedding & furniture
- Building insulation
- Carpet underlay
- Geotextiles
- Hygiene
- Technical nonwovens
- And more ...



CONTENTS

Improve your flexibility with airlay lines	4
Develop your products in our technical center	6
Dedicated service	7
Foresee digitally with Metris	8
Airlay flexiloft line	10
Airlay resinfelt line	11
Opening	12
Blending	14
Storage	16
Airlay flexiloft machine	18
Airlay resinfelt machine	20
Bonding technologies	22
Edge trim recycling	24
Short fiber dosing	26
Controls and accessories	27



Improve your flexibility with airlay lines



FLEXIBILITY: AN IMPORTANT BENEFIT FOR AIRLAY LINES

The high flexibility of the airlay technology allows you to process all types of fibers from virgin, recycled fibers to non-fiber particles such as foam, shredder paper, and straw. This technology can guarantee homogeneity and mat regularity for a large range of weights from 300 to 12,000 gsm. The airlay line offers a working width from 1.5 to 4.0 m.



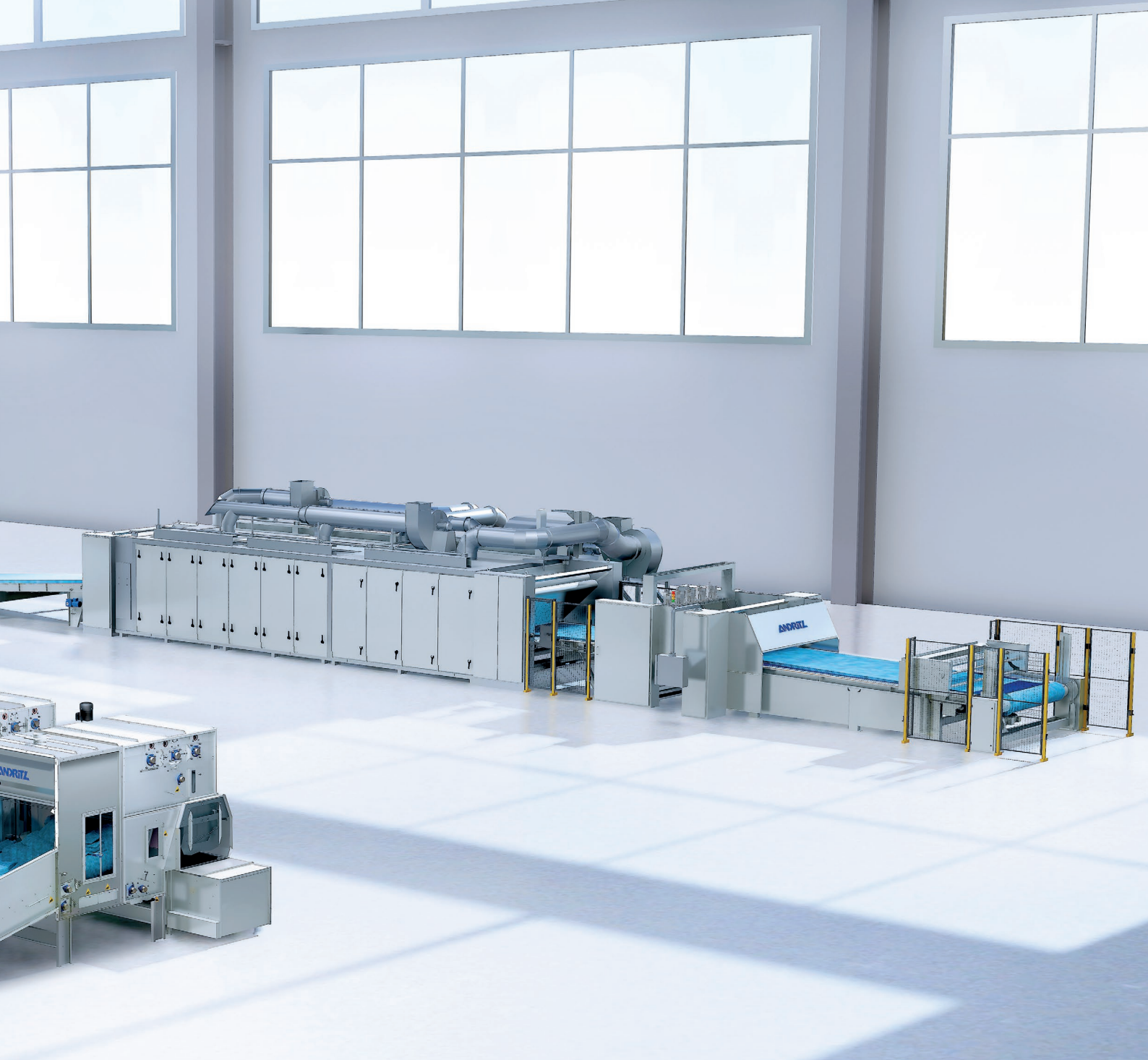

EASY MAINTENANCE

Our airlay line has been designed to facilitate cleaning, reduce maintenance, and minimize energy consumption. This makes it operator-friendly, combining sturdiness and easy access to all parts, thanks to their ergonomic design.

PROJECT MANAGEMENT

With close to a century of experience in the fine art of textile and nonwoven processes, we offer high-quality, efficient, and proven solutions that provide our customers with time savings, safety, and production line efficiency. Thanks to our high level of expertise, we work in harmony with our customers to deliver the requested end product.

Develop your products in our technical center

A high level of expertise to fit your needs: Our technical center allows you to test and prove technical solutions on industrial lines and to get the most out of your investment with the support of highly skilled engineers. You can benefit from more than a century of expertise.

EXPERIENCE NEW PRODUCTS

We offer you the chance to test our tearing process. Benefit from our expertise and create opportunities to reinforce your market or to access or create new ones.

RESEARCH AND DEVELOPMENT

We continuously enhance our machines to improve aspects such as safety or reduce energy consumption. We also consistently develop new solutions for new textile articles and raw materials entering the market.

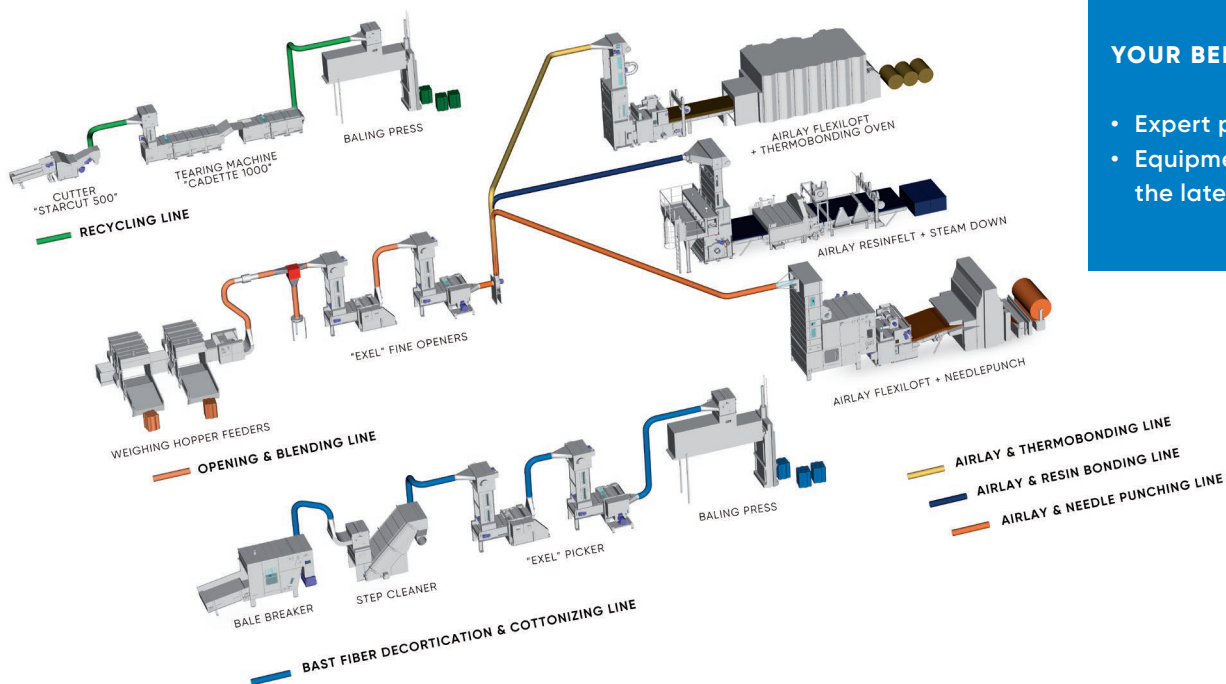

YOUR BENEFITS

- Expert process support
- Equipment based on the latest technology



ANDRITZ technical center in Cours, France



Dedicated service

We know how important uptime is for your production efficiency. That's why we do everything to keep interruptions to a minimum. With remote maintenance and a highly responsive service team, we can deal with any issues in the shortest time possible.

SPARE PARTS

To ensure the longevity and the performance of your equipment, we recommend using only original spare parts from ANDRITZ. Our sales team for spare parts is at your disposal to help you choose the right parts.

UPGRADES AND RETROFITS

Our specialists are available to inspect your production lines and propose improvements to extend the product life of your equipment or increase productivity.

SKILLED TECHNICIANS AT YOUR DISPOSAL

With the goal of providing a service that is as efficient and responsive as possible, we assign a dedicated team of skilled technicians as well as automation and textile engineers.

ONLINE SUPPORT

We want to support you at all times. You can always rely on a competent partner to explain any problems related to textile, mechanical, or electrical/electronic issues.



YOUR BENEFITS

- Service centers around the globe
- Technical and electrical diagnosis by experts
- Complete stock of original parts
- Assistance with installation, operation, maintenance, and training
- Improve your production operations
- Enhance the performance of your equipment

Foresee digitally with Metris

Industrial Internet of Things (IIoT), Industry 4.0, digitalization – these are current buzzwords that industries use when seeking to improve their performance and equip themselves for the future of industry.



ANDRITZ DIGITAL SOLUTIONS

As a technology leader with extensive and long-term experience in supplying industrial measurement, control, and optimization solutions for various industries, ANDRITZ combines process and equipment expertise with the latest enhancements in the digital era. The result of this powerful combination is Metris: a portfolio of ANDRITZ Digital Solutions.

METRIS OPP

One of the flagship capabilities of the Metris assortment is its ability to optimize industrial processes with Metris OPP. It has been developed over the past decade within the pulp and paper sector and has been introduced to the nonwovens industry. It combines powerful analytical and data mining software with the knowledge of the world's top process experts to deliver a smart service initiative for customers.





A CONSTANTLY GROWING PORTFOLIO

The depth and effectiveness of the Metris portfolio continues to improve thanks to ongoing R&D, collaboration with key customers and institutions, and venture activities. Portfolio options all rely on the three strategic focus areas of the Metris brand:

Industrial IoT technologies, Smart Service concepts, and venture activities. The main technological advancements integrated into individual Metris products are derived from big data analytics, smart sensor technologies, and augmented reality solutions. The Metris UX platform providing full support throughout the entire

lifecycle of a plant is the most recent of our IoT developments. With Metris solutions, customers gain digital foresight thanks to the continuously improved portfolio and its performance – and to ANDRITZ providing tailored and fully integrated digital solutions from a single source.

Benefits

Metris - ANDRITZ Digital Solutions

- **IIoT solutions across business segments**
- **Combined know-how from ten years of experience of Metris OPP**
- **Using the latest smart sensor technologies**
- **Big data analysis with tried-and-tested models for deviation analysis**
- **Providing information locally with augmented reality**
- **Extensive solution and process engineering knowledge**
- **Cyber security solution to safeguard data on the network**

Airly flexiloft line

Unlimited opportunities: Our airly flexiloft line has been designed to form mats from all types of fibers from short recycled fibers to long, coarse natural, or special inorganic fibers and blends with non-fiber particles such as plastic, foam, wood chips, or feathers.

The airly flexiloft line with its Density Control Measurement (DCM) allows the most accurate mat weight and can range from 300 to 6,000 gsm, or up to 12,000 gsm with the "flexiloft+" option. The flexiloft technology allows a higher thickness, increases resiliency, and improves the acoustic and thermal

properties of the felt. It also avoids segregation of components across the thickness of the mat and provides a perfect homogeneity between the fiber particles.



Airly flexiloft line

YOUR BENEFITS

- Flexibility regarding raw materials
- Very low maintenance cost
- Lower space and power footprint
- High thickness
- Avoids segregation

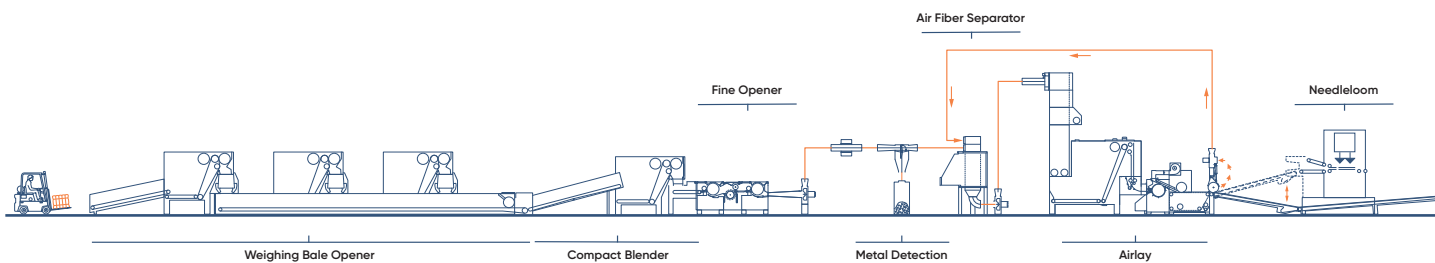

Schematic diagram of ANDRITZ airly flexiloft line

Airly resinfelt line

Innovative process for the production of semicured resinated felts: Our airly resinfelt line is designed for the automotive and/or the appliance industries. It can deliver weights ranging from 200 to 2,000 gsm.

The airly resinfelt line retains the advantages of true air forming technology and uses a close recycle loop with resin powders, thus allowing a dust-free environment. The resinfelt is especially designed to

process resins such as phenolic or epoxy mixed into the mat with an excellent resin distribution. It is easy to clean, requires little maintenance, and has a low energy consumption.



Airly resinfelt line in operation

YOUR BENEFITS

- Uniform fibers and resin distribution
- Easy cleaning and dust-free environment
- Smaller footprint

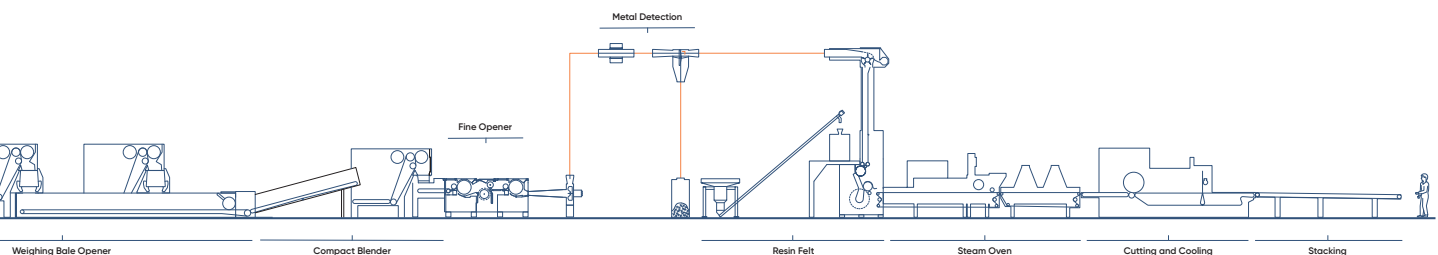
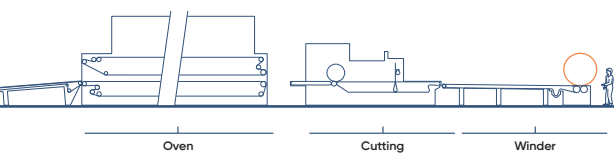

Schematic diagram of ANDRITZ airly resinfelt line

Opening

Meeting market needs: We offer several ranges of opening machinery, which are available depending on the application, raw materials, line configurations (airlay, airlaid, carding, dosing), and bonding technologies (thermobonding, chemical bonding, needling, spunlacing, calendering, stichbonding, and many more).

Type	PO	OH
Working width	1 - 1.5 m	1 - 1.5 - 2 m
Productivity	up to 2 t/h/m w.w.	up to 1.5 t/h/m w.w.

THE PRE-OPENER (PO) has been designed for high production and gentle opening blending. The pre-opener includes a feeding conveyor with two pressing rollers and a batts cylinder.

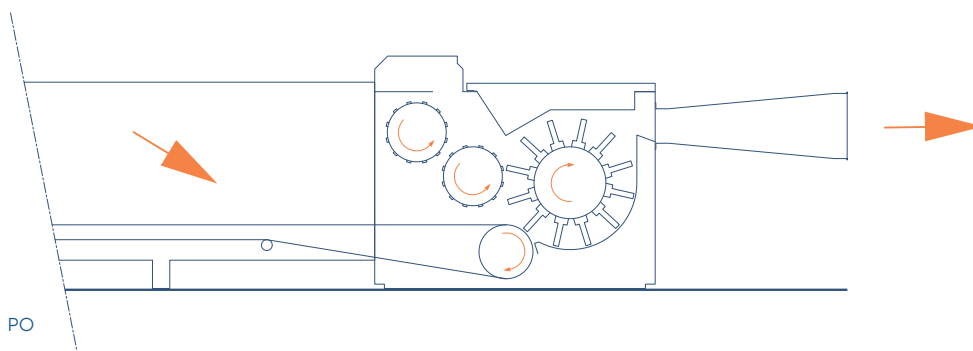

THE HORIZONTAL OPENER (OH) is designed with a feeding conveyor, pressing roller, a pair of feed rollers and a fully pinned opening cylinder for an intensive opening and blending action. Our horizontal opener is designed to process all types of fibers including recycled, natural fibers, as well as cut/shredded parts such as foam, paper, cardboard, wood, nonwovens, and many more. The horizontal opener can be tailor-made with galvanization coating or stainless steel coverage, with a wide range of pins or wire clothing opening cylinders.

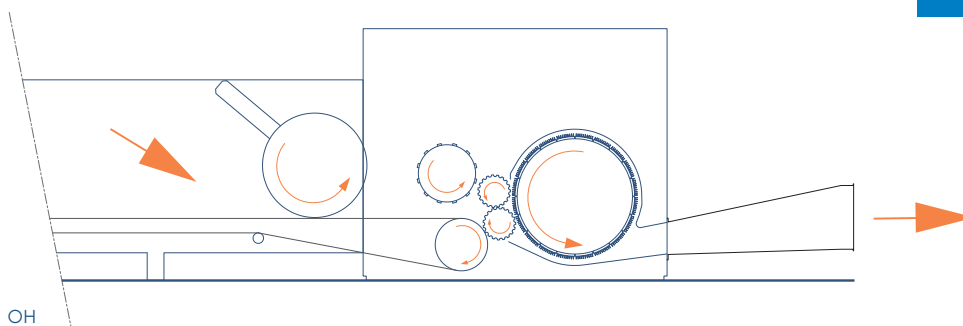

YOUR BENEFITS

- Customized solution for all types of raw materials
- Low space and energy footprint
- Easy cleaning and maintenance

THE EXEL FINE OPENER is designed for fine opening and intimate fiber blending for airlay products. It is customized for many applications thanks to a dedicated combination of a feed dish, a wide range of feed rollers, and a pinned or wired opening cylinder. It is available with 1 to 3 opening sections

for a more intimate fiber blend. As an option, a sorting system could be added to eliminate unopened bits or heavy foreign particles. Adjustable settings such as the distance between the feed dish and opening cylinder, while running, allow you to optimize the opening and blending efficiency.

Type	EXEL
Working width	1 - 1.5 - 2 m
Productivity	up to 1 t/h/m w.w.*

*According to raw materials, requested specification, and end-use products

YOUR BENEFITS

- Sturdy design and smooth opening at high production rates
- Extreme flexibility
- User-friendly

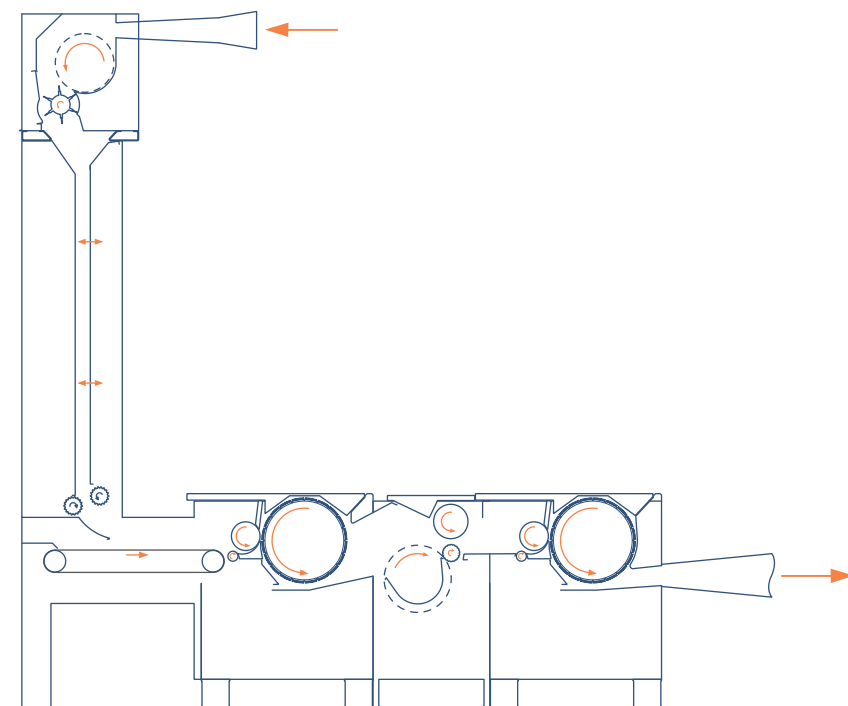

EXEL 2C fine-opener



Blending

Guarantee of ultimate precision: Our blending machines are designed to supply a consistent, accurate and intimate blend of opened fibers to downstream equipment. With the self-optimizing speed adjustment, our new weighing feeder does not require any action from the operator, thus leading to higher production and better weighing control.

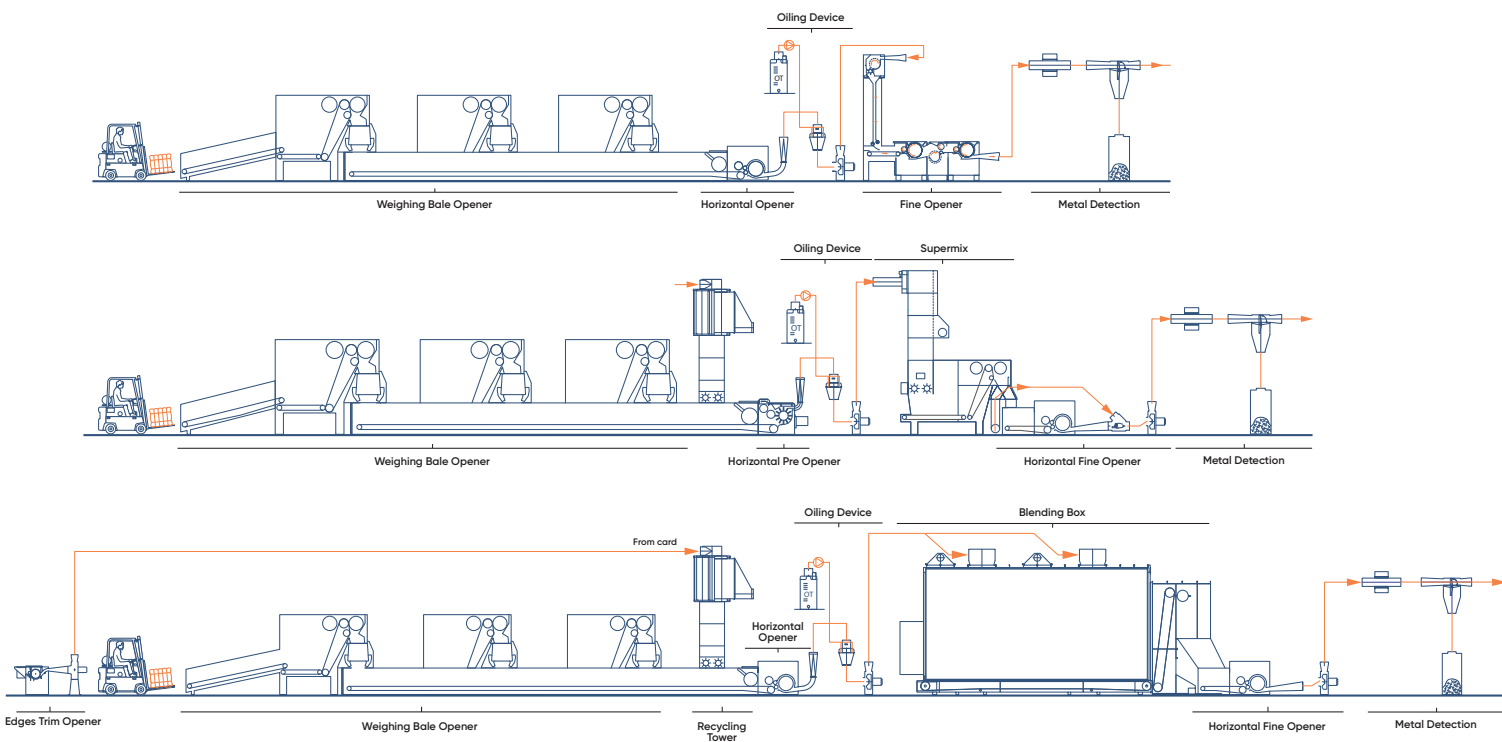
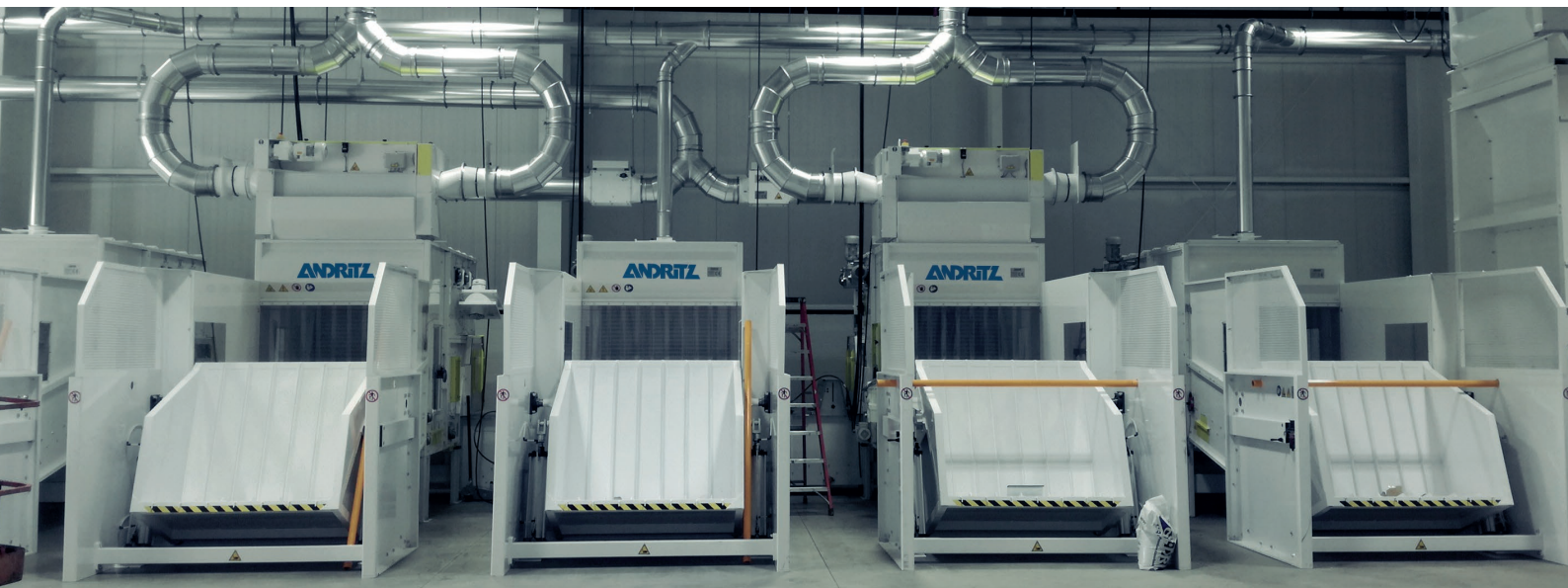

Schematic diagrams of ANDRITZ blending line



YOUR BENEFITS

- Operator-friendly
- Extremely flexible
- Accurate and high capacity
- Self-optimizing setting
- Tailor-made according to end use
- Low space and energy footprint



Ease of operation, visibility, productivity, reduced maintenance, and lower power consumption have been the key words in the development of our new weighing bale opener.

The weighing bale opener is available with a working width of 1.2, 1.6, and 2 m with a reinforced bale feeding conveyor from 2.4 to 9.9 m. The new design of the weighing bale opener has a higher blend accuracy thanks to new load cells and self-optimizing speed adjustment with a capacity of up to 1 t/h/machine.

This standard weighing bale opener is designed to process all types of fibers including all recycled and natural fibers, from a length of 1 to at least 120 mm and from 0.8 to 200 den as well as cut/shredded parts such as foam, paper, cardboard, wood, nonwovens, and many more.

Thanks to its special design, our weighing bale opener allows high flexibility in terms of the fiber opening degree. We offer the opportunity to tailor the weighing bale opener according to end use, such as dedusting device, positive pressure on spike conveyor, automatic gap adjustment and/or type of evener roller, galvanization coating, or stainless steel coverage.

Storage

Smooth production process: For compact blender storage, the supermix blender (SMIX), with a low space footprint and efficient blending, allows flexibility and quick production changeover. For long-term blender storage, the SM blending box can be configured in line with customer requirements.

Type	SMIX	SM	CM
Working width	1.6 - 2 m	3 - 3.9 m	3 - 3.9 m
Productivity	up to 1 t/h/m*	up to 1 t/h/m*	up to 1 t/h/m*

*According to raw materials

THE SUPERMIX is designed to process all types of fibers including recycled and natural fibers as well as cut/shredded parts such as foam, paper, cardboard, wood, nonwovens, and many more.

It has a self-optimizing speed adjustment which can reach a capacity of up to 1 t/h/m per machine and is designed to allow quick production changeover.

We offer the opportunity to tailor the supermix according to end use, such as a dedusting device, positive pressure on spike conveyor, automatic gap adjustment and/or type of evener roller, galvanization coating, or stainless steel coverage.

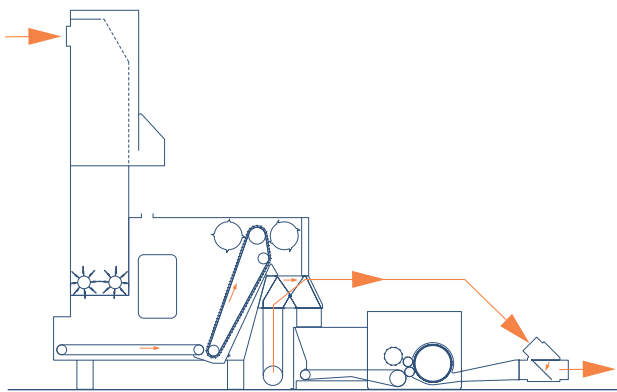

SMIX - OH

YOUR BENEFITS

- Easier maintenance
- Low space footprint
- Compact blender
- Fast cleaning
- Quick production changeover

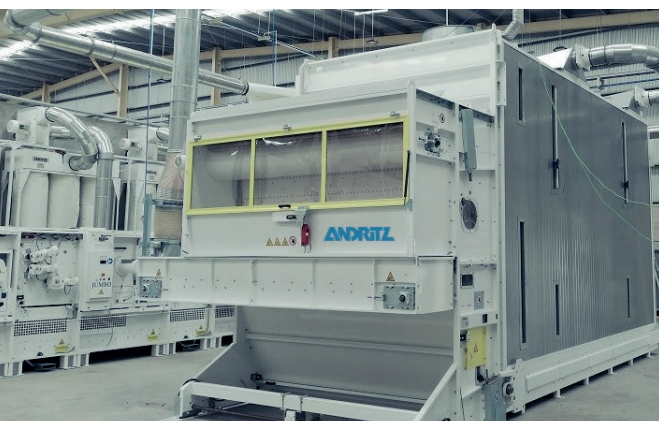

Blending box

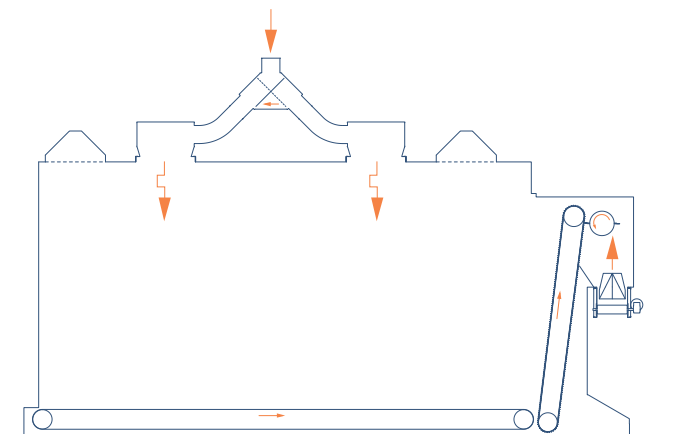



Airly flexiloft machine

Many opportunities for airlay web forming: All virgin, recycled, natural, and mineral fibers and particles such as paper, foam, wood, and many more can be processed with our airlay flexiloft machines.

Type	Airly flexiloft	Airly flexiloft+
Working width	1.1 to 4.0 m	2.2 to 4.0 m
Mat weights	300 to 12,000 gsm	
Productivity	1 t/h/m*	1 t/h/m*
Fiber length	1 to 100 mm*	
Fiber fineness	0.8 to 150 den	

*According to fiber

YOUR BENEFITS

- Better control of the MD:CD web profile
- Self-regulating raw material distribution across the entire width
- Higher weight range
- Fast overchange production
- Easy cleaning and dust-free environment
- Operator-friendly and low maintenance

MULTI-DENSITY WEB FORMING (PATENTED)

The multi-density web forming system has been especially developed to offer a process capable of single and multiple densities and can run two different blends. This equipment increases the density in strategic parts of the mat to reinforce areas for the automotive and bedding industries.

Thanks to its density control system, the multi-density web forming system allows a high weight accuracy.

Using this equipment leads to substantial cost savings in material use, avoiding useless additional weight on the mat.

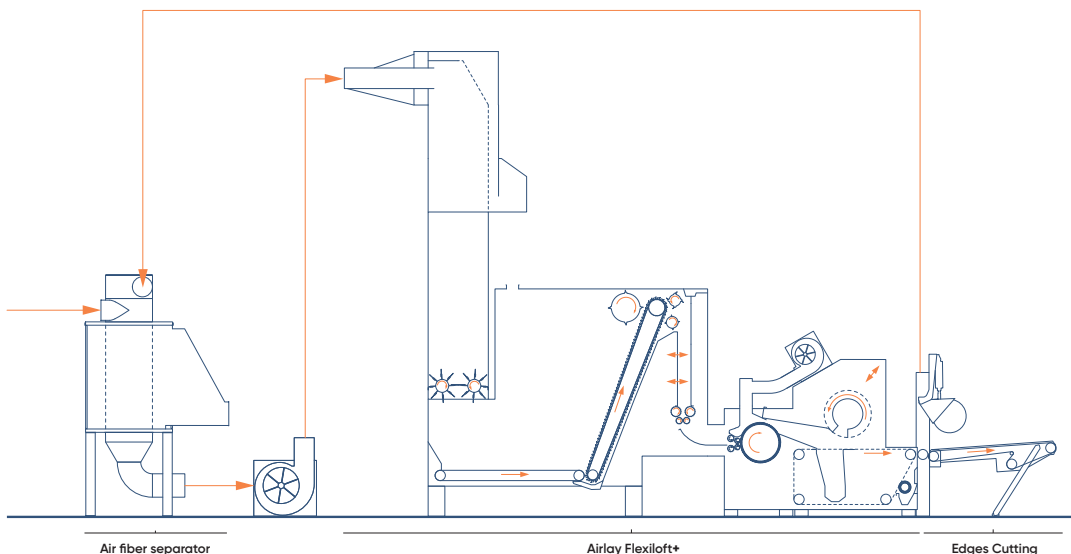



Airly flexiloft line

Examples of product compositions:

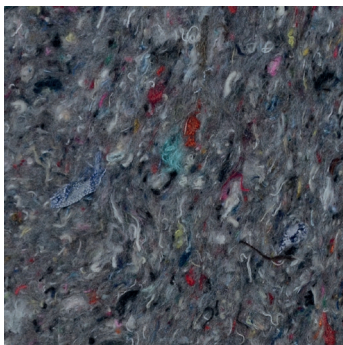

100% cotton recycling fiber



100% hemp



100% paper



100% white polyester

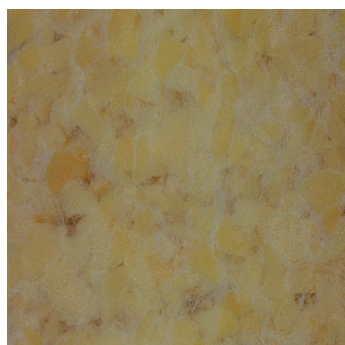

100% foam bico

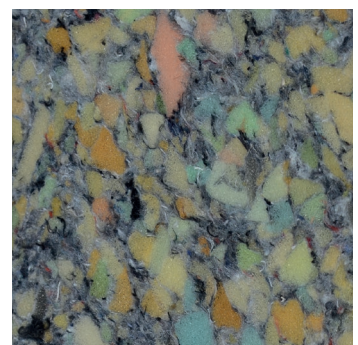

Mixed foam & recycled cotton fiber

Airlyay resinfelt machine

Produce semicured resinated felts: This machine is perfectly designed for flat and molded parts in the automotive and appliance industries. A wide range of fibers and particles can be processed with our airlyay resinfelt.

Type	Airlyay resinfelt
Working width	2.4 - 2.6 m
Mat weight	200 to 2,000 gsm**
Fiber length	1 to 50 mm*
Fiber fineness	0.8 to 15 den
Productivity	up to 0.5 t/h/m**
Resin type	Epoxy, phenolic...
% of resin	up to 35%

*According to fiber

**According to raw materials, requested specification, and end-use products

YOUR BENEFITS

- Separate flows for the fiber and resin
- Adjustable scattering for resin distribution across the entire width
- Fast overchange production
- Easy cleaning and dust-free environment
- Operator-friendly and low maintenance





Bonding technologies

Robust and reliable for consistent quality: We offer several bonding technologies for our airlay lines such as needling, thermobonding and hydroentanglement depending on customer needs.

THERMOBONDING

Thermobonding felts are ideal for high thickness and density, and are especially designed for insulation in various sectors such as the building, automotive, bedding, and furniture industries.

YOUR BENEFITS

- One turnkey supplier
- High efficiency
- Durable equipment
- ANDRITZ digital solution (Metris)



Airlay line with an oven in operation

HYDROENTANGLEMENT

As a result of its unique experience in the spunlace industry, ANDRITZ offers the widest range of Jetlace hydroentanglement units to cover the needs of all nonwovens producers around the world.

YOUR BENEFITS

- Customized design
- Compact configuration
- Energy efficiency
- High capacity over the whole gsm range
- Experience at up to 1,000 m/min
- ANDRITZ digital solution (Metris)

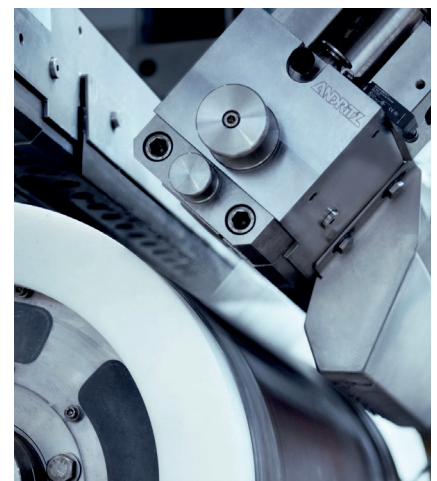

NEEDLEPUNCHING

The ANDRITZ needleloom range offers a variety of punching speeds and working widths. The needlepunch felt has a higher mechanical characteristic strength. ANDRITZ eXcelle needlelooms use the technology based on oil-lubricated modules with a patented

guiding piston design. Oil keeps the bearing at the optimum working temperature, securing long-lasting use. Needleboard patterns have been adapted for an optimum visual appearance and high versatility throughout wide ranges of advance pitch.

OPTIONAL EQUIPMENT

- Dynamic Harmonic Shifter (DHS) for needling process with heavy punching load
- Quick exchange of bed / stripper plate
- Intermittent air blowing network
- Dedusting suction systems
- Heavy-duty delivery press
- Magnetic bars
- Pneumatic centralized needleboard pinning system

YOUR BENEFITS

- Highly durable equipment
- Wide range of possible needling densities
- Clean environment
- Low maintenance requirement with change of oil after 14,000 working hours
- Easy cleaning and maintenance
- Low cleaning requirement
- ANDRITZ digital solution (Metris)



Needleloom in operation

Edge trim recycling

Aiming for zero waste: Our Supertrim and Minitrim have been especially designed to recycle edge trims. This system aims to completely eliminate waste in your process.

Type	SUPERTRIM	MINITRIM	MINITRIM HSP
Working width	500 mm - 1 m	200 mm	200 mm
Feeding speed	up to 50 m/mn	up to 40 m/min	up to 250 m/min
Options	Feeding conveyor Water spraying system	Water spraying system Unwinding system for "roll goods"	

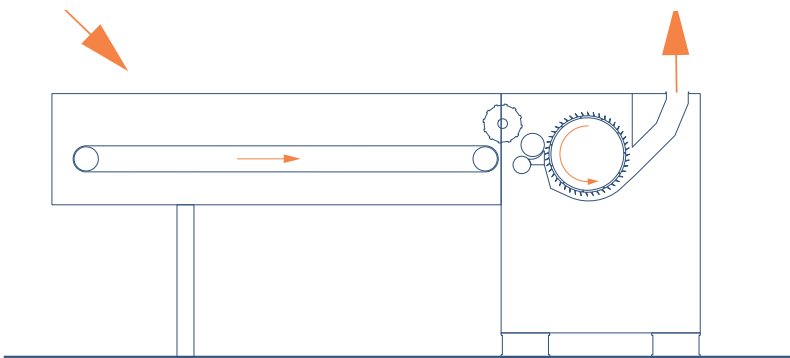

Supertrim unit STRIM C

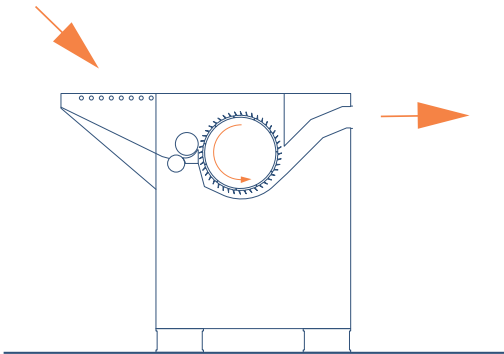

Supertrim unit STRIM

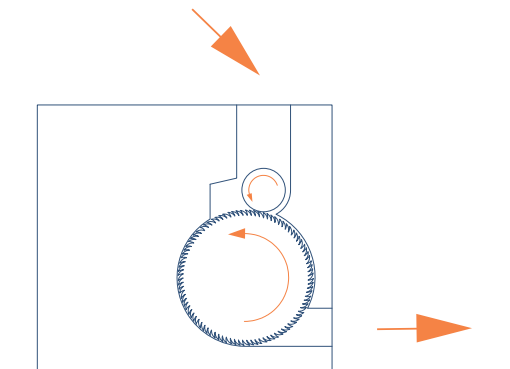

Minitrim unit MTRIM

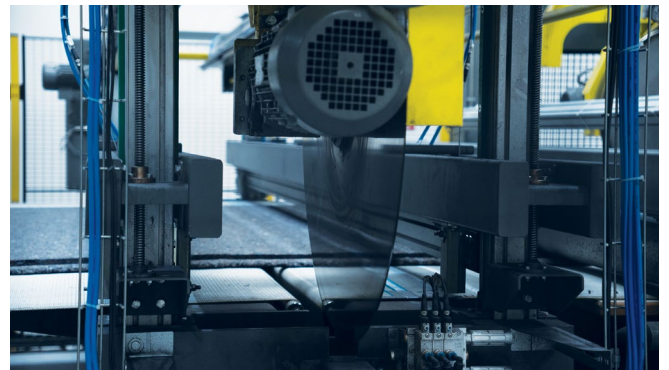

Edge trim recycling unit in operation



Automotive raw material before process

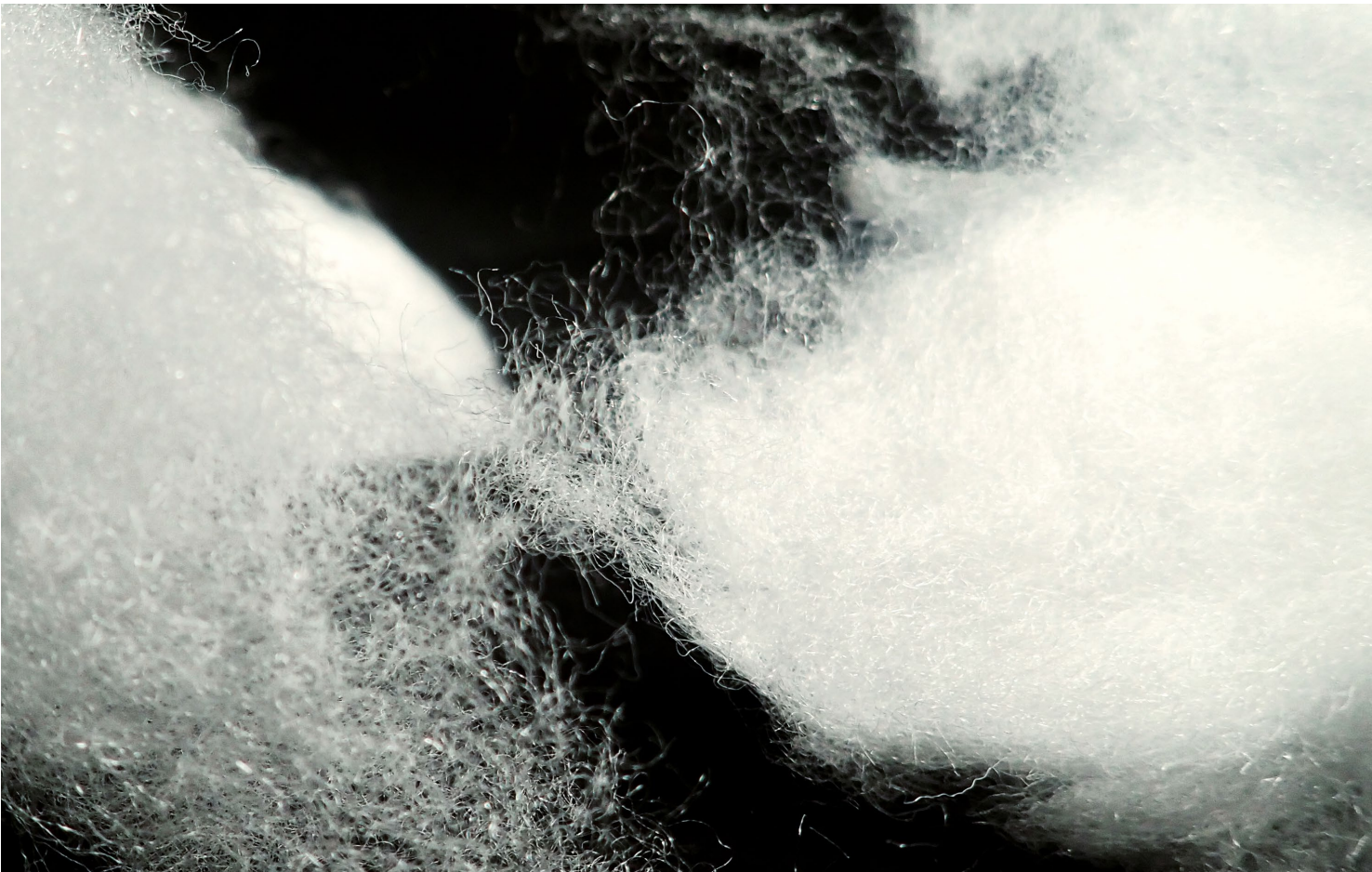

Fibers after process

Short fiber dosing

Increase your precision: The short fiber dosing system has been designed to open fiber bales and to accurately meter a flow of fibers into a downstream process (airlaid paper, diaper machines...).

Type	CD 500/1000
Production rates	from 50 to 1,000 kg/h
Width range available	from 500 mm - 1 m

YOUR BENEFITS

- Highly accurate
- Controllable continuous fiber mass flow rate

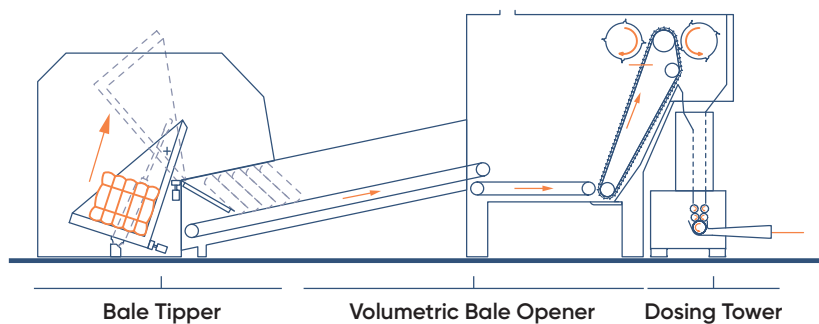

Short fiber dosing unit

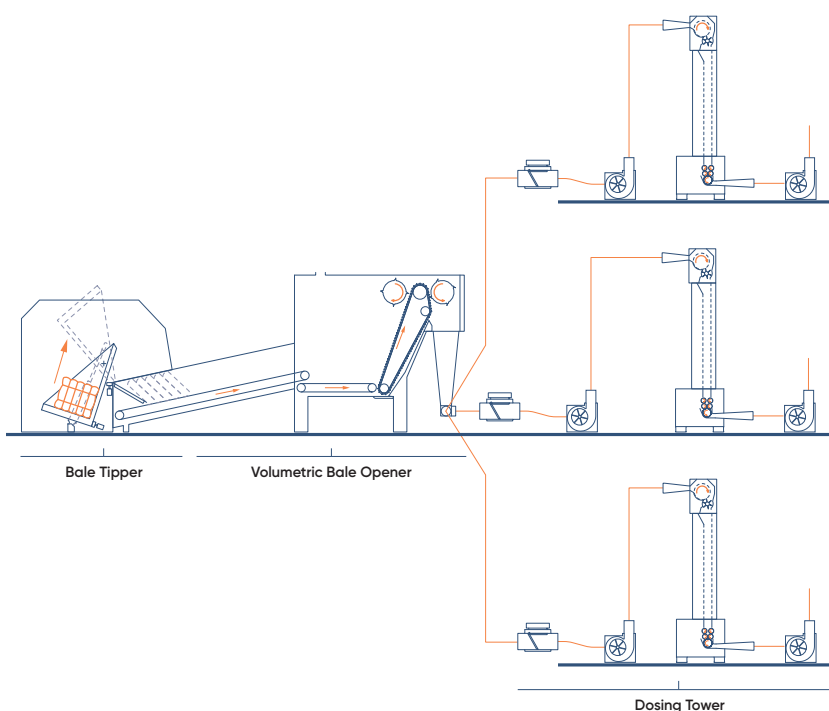

Controls and accessories

FILTRATION UNIT

We offer a centralized filtration system with a pre-filter, drum filter and cyclones equipped with a permanent self-cleaning system. This unit allows a constant flow of dusting and low maintenance thanks to its dust compacting system.

METAL DETECTION

The airlay line is also available with a highly sensitive metal detection and automatic rejection of contaminated materials which can be combined with a fire detection system. The metal detector ensures the complete absence of metallic material in the web.

FIBER LUBRICATION SYSTEM

Fiber lubrication is based on a compact system with a reserve tank, metering pump, and atomizers. The lubrication allows you to prevent static electricity in the fibers and also to limit the strain on the needles, thus preventing wear when needling the web.



Filtration unit

GET THE MOST OUT OF YOUR INVESTMENT

At ANDRITZ Nonwoven and Textile we know that your business depends on satisfied customers and efficient processes. That's why we support you in every aspect of your nonwoven and textile production. Take advantage of technology that will let you produce consistent quality for decades to come. Benefit from the highly efficient use of energy and raw materials that our production provides. You can rely on our responsive service teams to protect your investment and optimize your processes. Experience how innovative approaches and digital services give you more control than ever before. With ANDRITZ, the leading supplier for the nonwoven and textile market, you get the most out of your investment.

FRANCE

ANDRITZ Laroche SAS
Cours-la-ville, France
p: +33 4 74 89 84 85
laroche@andritz.com

ANDRITZ Perfojet SAS
Montbonnot, France
p: +33 4 76 52 23 11
perfojet@andritz.com

ANDRITZ Asselin-Thibeau SAS
Elbeuf, France
p: +33 2 32 96 42 42
asselin-thibeau@andritz.com

GERMANY

ANDRITZ Küsters GmbH
Krefeld, Germany
p: +49 2151 34 0
kuesters@andritz.com

ITALY

ANDRITZ Diatec Srl
Collecovino, Italy
p: +39 085 82060-1
diatec@andritz.com

DENMARK

ANDRITZ Dan-Web A/S
Galten, Denmark
p: +45 87 43 95 00

CHINA

ANDRITZ (China) Ltd.
Wuxi branch office
Wuxi, P.R. China
p: +86 510 8536 1269
nonwoven-china@andritz.com

INDIA

ANDRITZ Technologies Pvt. Ltd.
Chennai, India
p: +91 44 4293 9393
nonwovenservice.india@andritz.com

USA

ANDRITZ Inc.
Spartanburg, USA
p: +1 864 587 4848
nonwoven-america@andritz.com

[ANDRITZ.COM/AIRLAY](https://www.andritz.com/airlay)

JOIN US ON SOCIAL MEDIA



ANDRITZ

All data, information, statements, photographs, and graphic illustrations in this leaflet are without any obligation and raise no liabilities to or form part of any sales contracts of ANDRITZ AG or any affiliates for equipment and/or systems referred to herein. © ANDRITZ AG 2023. All rights reserved. No part of this copyrighted work may be reproduced, modified, or distributed in any form or by any means, or stored in any database or retrieval system, without the prior written permission of ANDRITZ AG or its affiliates. Any such unauthorized use for any purpose is a violation of the relevant copyright laws. ANDRITZ AG, Stattegger Strasse 18, 8045 Graz, Austria. Airly brochure 1.0/09/2023 EN

